

**MAC 10<sup>®</sup> LEDC**  
4x4 Fan Filter Unit  
Standard, RSR, & RSRE Models  
**OPERATION & MAINTENANCE MANUAL**

## Table of Contents

Critical Operations of the MAC 10 <sup>®</sup> .....	3
Part numbers .....	3
Warnings .....	4
Installation .....	5
Unit Control Box .....	6
Universal Control Card Set Up .....	7
Troubleshooting.....	12
Service: Removal and Replacement of Standard Filters.....	13
Service: Removal and Replacement of RSR/E Filters .....	14
Service: Standard and RSR Motor Removal and Installation.....	15
Service: RSRE Motor Removal and Installation .....	16
MAC 10 <sup>®</sup> LEDC Wiring Diagram.....	17
MAC 10 LEDC Replacement Parts List.....	18
Limited Warranty .....	19
Testing .....	19

Installation & Service Manual

■ **Critical Operation Conditions of the MAC 10**

1. Touching of the HEPA filter will damage it, voiding the warranty on the filter. The screen is only to protect against an accidental 'touch' of the filter. Never place a hand or tool on the filter. Never lie filter face flat down on a surface always have filter on its side to protect from damage.
2. Prior to powering the unit, verify that the unit has been wired into the correct voltage. The serial number label on the top of the Mac 10 unit has the required voltage.
3. To insure you order the proper replacement parts or complete MAC 10 unit, record the part number and serial number. This information is located on the serial number label, located adjacent to the electrical box. If you can't locate the Sales Order Number, please contact ENVIRCO for this information.

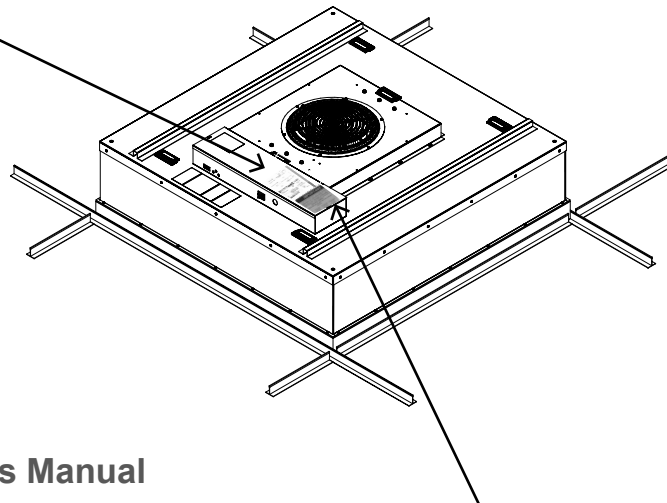

■ **Part Numbers Covered by this Manual**

11185-XXX	MAC 10 LEDC 4x4	Standard Filter
11233-XXX	MAC 10 LEDC 4x4	RSR Filter
11233-ZXXX	MAC 10 LEDC 4x4	RSRE Filter

Note: A 'Z' in the part number indicates that the unit is special. This may indicate a size change from standard or a special filter. Please contact the factory for part numbers if this is the situation.

**IMPORTANT**

YOUR FAN FILTER UNIT HAS THREE MODES OF OPERATION. IT IS YOUR RESPONSIBILITY AS THE INSTALLER TO SET THE MODE AS REQUIRED. IF UNSURE CONTACT YOUR PROJECT MANAGER OR CONTROLS COMPANY. THE MODES ARE SET BY SETTING THE 2 PIN DIP SWITCH.

MANUAL MODE 1 OFF 2 OFF	ANALOG MODE 1 ON 2 OFF	NETWORK MODE 1 OFF 2 ON	NETWORK MODE 1 ON 2 ON

Units come set in manual mode from the factory. Please review installation requirements and set up with your end user (See page 8 for complete set up instructions).

### Installation & Service Manual

#### ■ Warning

TO REDUCE THE RISK OF FIRE, ELECTRICAL SHOCK, OR INJURY TO PERSONS, OBSERVE THE FOLLOWING:

- A. Installation work and electrical wiring must be done by qualified person(s) in accordance with all applicable codes and standards, including fire-rated construction.
- B. When cutting or drilling into wall or ceiling, do not damage electrical wiring and other hidden utilities.
- C. If this unit is to be installed over an area using liquid, such as water or chemical cleaning solutions, it must be marked as appropriate for the application.
- D. Use this unit only in the manner intended by the manufacturer. If you have any questions, contact the manufacturer.
- E. Before servicing or cleaning the unit, switch power off at unit service panel and lock service panel to prevent power from being switched on accidentally.

#### **ENVIRCO USA**

101 McNeill Road  
Sanford, NC 27330  
Tel: (919) 775-2201  
Tel: (800) 884-0002  
Fax: (800) 458-2379  
Email: [info@envirco.com](mailto:info@envirco.com)

#### **ENVIRCO Europe**

Ruskin Air Mangement  
South Street, Whitstable  
Kent, CT5 3DU, UK  
Tel: +44 (0) 1227.276100  
Fax: +44 (0) 1227.264262  
Email: [sales@envirco.co.uk](mailto:sales@envirco.co.uk)

#### **ENVIRCO Asia**

Johnson Controls Hong Kong Limited  
12/F., Octa Tower  
8 Lam Chak Street  
Kowloon Bay, Hong Kong  
Tel: +852.2590.0012  
Fax: +852.2516.5648

Installation & Service Manual

■ **Installation**

Note: The MAC 10 LEDC Fan Filter Unit is completely assembled at the factory with the exception of the optional 1/4" (0.64 cm)-20 eyebolts that are used when hanging the unit from an engineered design support system and installation of the HEPA/ULPA filters (eyebolts not included and need to be ordered separately, p/n 222449-001).

**Step 1.** Carefully remove the unit from the shipping carton and inspect for any damage that may have occurred during transportation (See Figure 1). Using the two handles attached to the lid, two workers minimum, are required to lift the unit from the box.

Recommendation:  
Review mode settings  
at this time as specified  
for installation  
(see page 7 for controls).

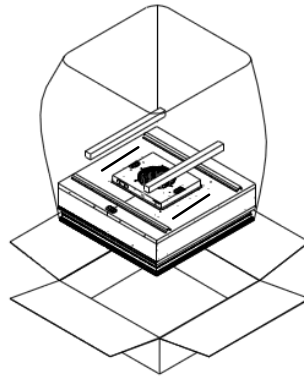

Note: When ordering RSR and RSRE units, the HEPA filters will be shipped separately to be installed into units after the fan box has been installed.

**Figure 1: Unboxing**

**Step 2.** If using rigidly supported grid (usually 2" (50 mm) or wider), raise unit through ceiling and lower onto the gasketed grid. If using a flexible grid (typically supported with wires), the unit must be secured to an engineered design support system with s-hooks and chain. Screw the four eyebolts into the nutserts on the lid assembly before lifting into an overhead position (see Figure 2). **Note:** Confirm fan dimensions to match T-grid dimensions.

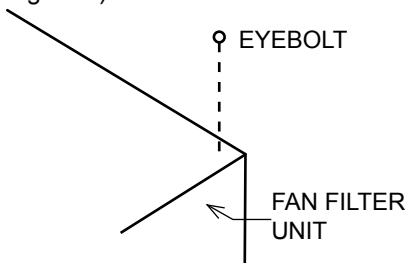

**Figure 2: Hanger Supports**

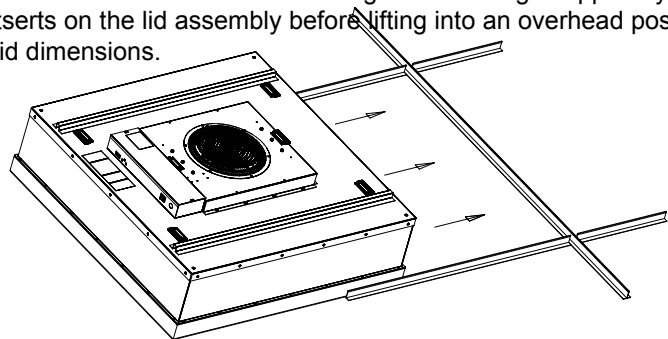

**Figure 3: Front Load Option**

**Step 2.1.** It is recommended that you front load your MAC 10 4x4 to your T-Grid system by running your main T-Grid and two cross Ts (install fan box into grid), then running your main T again (see Figure 3).

**Step 2.2.** If using a support grid, continue...

**Step 3.** Raise the unit and secure it into place using the chosen support system method suspended from a structural support bracing.

**Step 4.** Have an electrician wire the unit to the appropriate voltage, according to the wiring diagram (page 17), and all national and local electrical codes. All units are equipped with a three position terminal block for field connection. Verify correct single-phase power, before energizing units.

**Step 5.** Turn on the power using the two position rocker switch (ON/OFF) located on the electrical box. For RSR/E units, let the unit run for a few hours to purge off particulate that may be adhered to the inside of the unit before installing the filters. Do not run fan at full speed as this may cause overload condition.

Note: Your fan filter has been shipped separately.

## ■ Unit Control Box

### 2.1. ON/OFF Switch - Speed/Airflow Adjustment

All MAC 10 LEDC units are equipped with a two-position rocker switch (ON/OFF), which is located on the side of the electrical box, on top of the unit. All units are furnished with a Universal Control Card to enable adjustment of airflow or set to your means of communication. (see Page 7 for Universal Card Card Set Up).

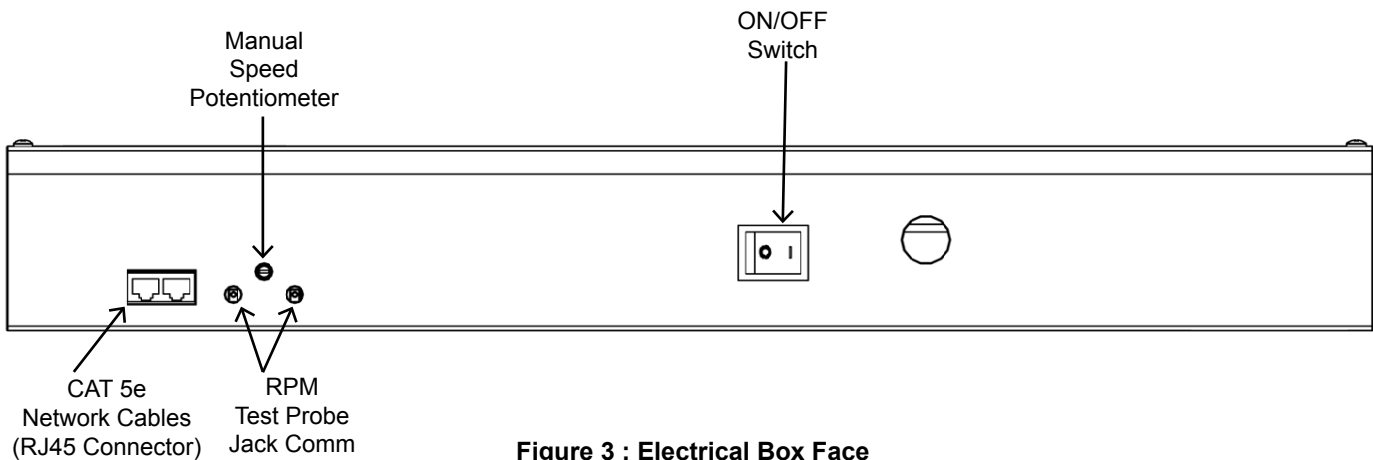

**Figure 3 : Electrical Box Face**

**Note:** The CAT5e/RJ45 network ports are non-directional (i.e. in or out). Be sure to examine your cabling to insure that there is no cross-over wired cables.

Installation & Service Manual

■ **Universal Control Card Set Up**

**UNIVERSAL CONTROL CARD - PRODUCT OVERVIEW**

ENVIRCO's ENV1028 Universal Control Card provides MODBUS network and analog control capabilities to an ENVIRCO Fan Filter Unit equipped with an electrically commutated motor. Three different control modes provide installation versatility by allowing the FFU to be controlled via MODBUS RTU network, analog 0-10 VDC control signal, or by adjusting the onboard potentiometer. The ENV1028 Universal Control Card is fully compatible with all of ENVIRCO's plug & play System Control Consoles using MODBUS RTU. Additional details of the controls modes are provided on page 8.

**FEATURES**

- Networkable Via MODBUS RTU
- 0-10 VDC Analog Control
- Manual Control Via Onboard Potentiometer
- Simple Connections
  - RJ45 For Networking Connection
  - Screw Terminals For Analog Control
  - Test Probe Jacks For DC mV Signal Output Of The Following...
    - RPM
    - Motor Control Set Point
- LED Diagnostics
  - Support for external LED (10mA) remote status notification via 2 Pin MTA connector
  - Onboard green LED for Board Status notification
  - Onboard red LED for Network Traffic
- Powered from Network or Local Supply

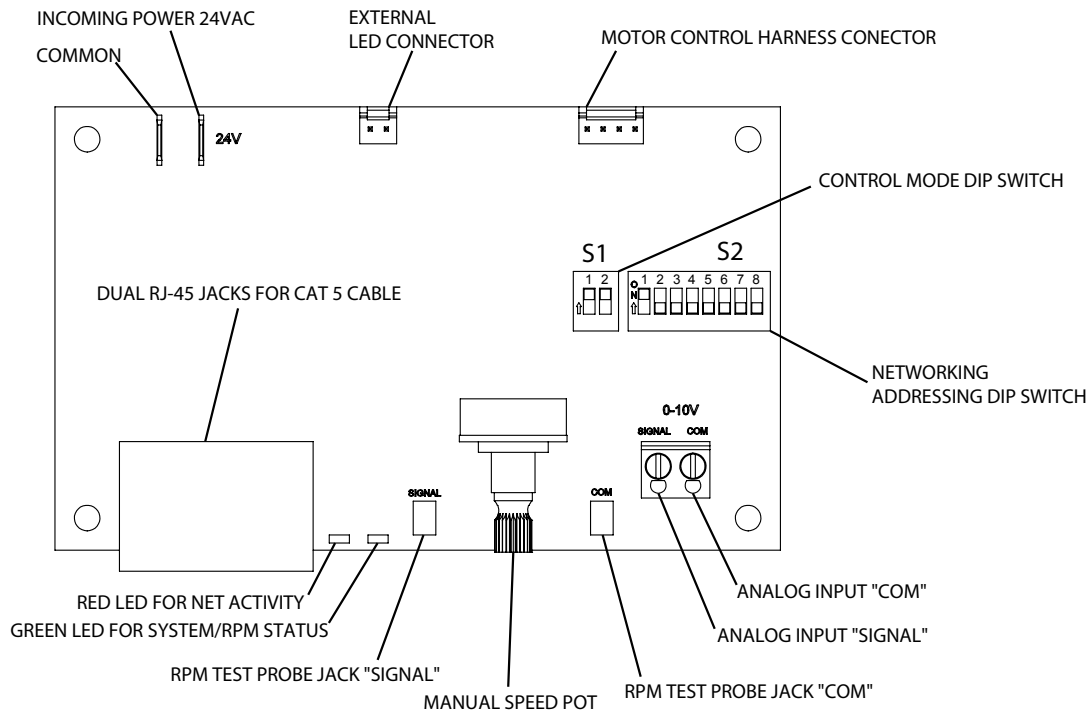

### Installation & Service Manual

#### CONTROL MODES

The ENV1028 operates in one of three selectable modes. The Mode is selected using DIP Switch S1.

- MANUAL control, on-board potentiometer
- ANALOG control, Remote 0-10 VDC
- NETWORK control, MODBUS RTU

Manual Mode = 1 OFF 2 OFF

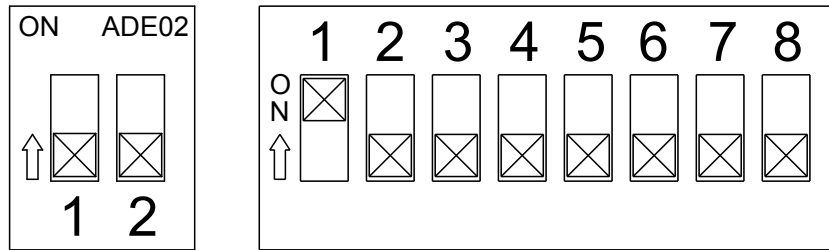

Analog Mode = 1 ON 2 OFF

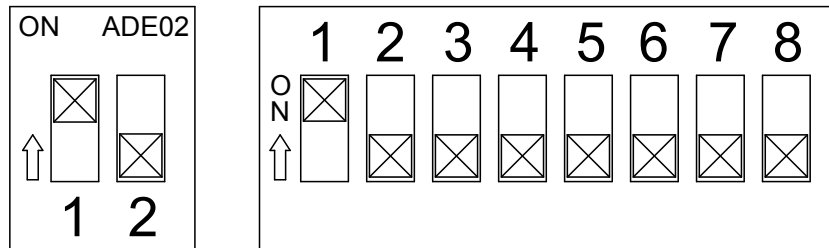

Network Mode = 1 OFF 2 ON

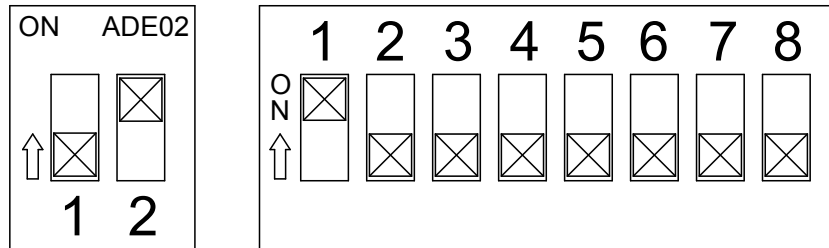

Network Mode = 1 ON 2 ON

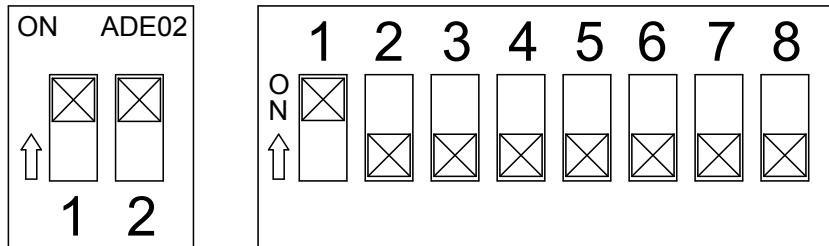

**Note: Network mode can be configured using either DIP switch setting shown above. DIP switch pictorials are for reference and may be labeled differently by the manufacturer.**



Installation & Service Manual

**Manual Control Mode:**

In Manual control mode, the motor speed is set using the onboard potentiometer. Onboard potentiometer rotation is CW to increase the motor output.

**Analog Control Mode:**

In ANALOG control mode, the motor output is set using an external 0-10 VDC demand signal.

**Network Control Mode:**

In NETWORK control mode, the motor output is set using MODBUS Register 2. Motor output is specified as a value from 0 to 100 representing a percentage of motor torque output. Each ENV1028 in a MODBUS network must be set to a unique address. The address value is **set in binary format using the eight DIP switches of switch bank (S2)**. A maximum of 200 ENV1028 devices is recommended per local area network(LAN). If an ENVIRCO ACC Control Console is the MODBUS master, then addresses should be assigned within the address range supported by the Control Console. Address zero should not be used as it is reserved for global commands. Address switch settings are only checked by the ENV1028 at power-up. Power must be cycled (OFF/ON) before any changes take effect.

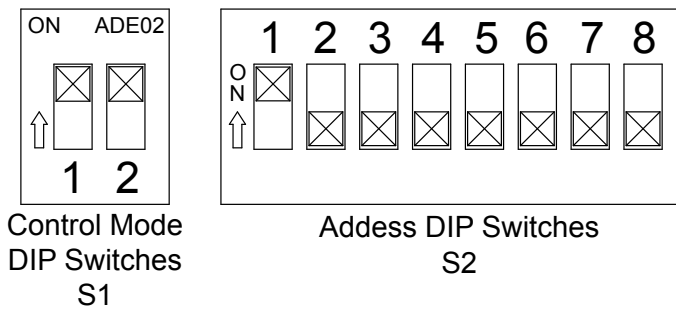

**Note: Network mode can be configured using either DIP switch setting shown above. DIP switch pictorials are for reference and may be labeled differently by the manufacturer.**

Registers relevant to this mode:

- Register 1 “Start/Stop” (R/W)
  - To enable motor, write a value of 1; To disable motor, write a value of 0
- Register 2 “Motor Set Speed” (R/W)
  - Motor Target speed value. Values may be written from 0 to 100
- Register 6 “RPM” (R)
  - Motor RPM. Read from the motor
- Register 12 “Actual Motor Speed Instruction” (R)
  - Speed control signal applied to the motor by the ENV1028.

(R/W) = Read/Write, (R) = Read Only

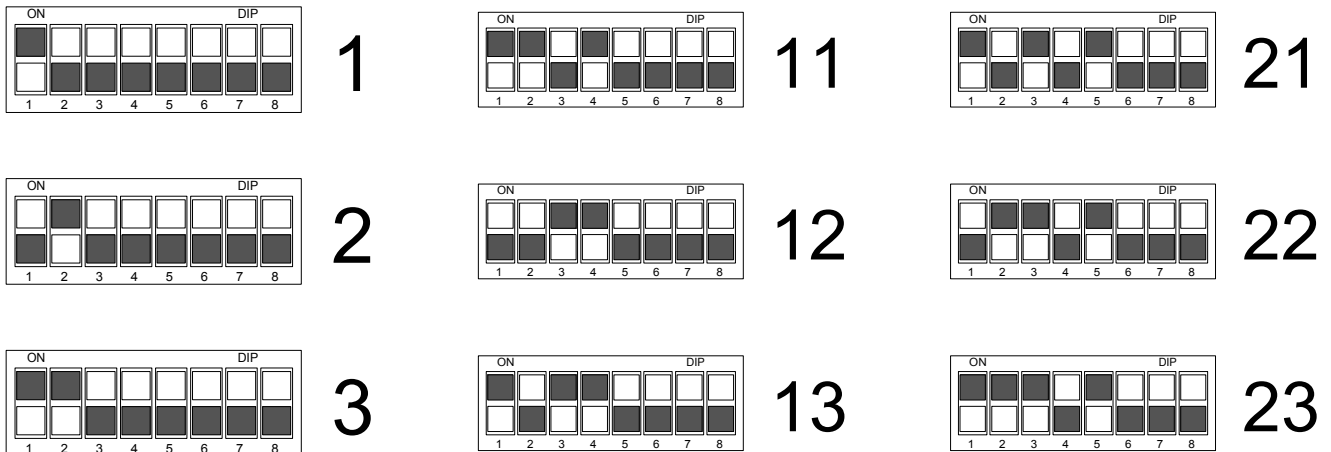

Example of binary S2 switch settings

### Installation & Service Manual

#### ELECTRICAL SPECIFICATIONS

Control and Interface Signals:

1. External Speed 0-10V Input
  - Input impedance 20k Ohms.
  - MIN ON-to-OFF threshold: 190mV\*
  - MAX OFF-to-ON threshold: 240mV\*
  - ON (~215mV) to 9.89V linearly scales 1 to 99% speed.
  - 9.89V or more deadbands to 100% speed.
2. External LED Output
  - 10mA regulated
  - LED forward voltages up to 5V
3. RPM Signal
  - Signal Value: mVDC = RPM
  - Ex: 900mV = 900RPM
  - RPM Output Range: ~ 0, 5 to 2000 RPM (0, 5mV to 2000 mV DC)
  - RPM Output Resolution: 5RPM (Zero, 400 steps from 5 to 2000 RPM inclusive)

#### Electrical and Environmental Specifications:

Specification	Min	Typical	Max	Units
Input Voltage	22	24	42	VAC
Supply Frequency	50	50/60	60	Hz
Input Power Consumption	na	na	0.5	VA
Ambient Operating Temperature	0	25	50	C

#### Test Probe JacksPoints:

The test probe jacks may be used to measure the motor rpm or the PWM signal that is being output to the motor.

- In Manual or Analog Control Mode with a S2 address setting of 1 or greater, the test probe jacks output 0-2000 mVDC representing motor RPM. By changing the address S2 switch to 0, the test probe jacks will output 0-1000 mVDC representing 0-100% demand signal to the motor. The address may be changed without interrupting power to the control card.
- In Network Control Mode, 0-2000 mVDC always represents RPM.

#### LED Indicators:

- Onboard Status LED:  
The Onboard Status LED is software controlled by the unit microcontroller. The Status LED is solid ON when RPM reported by the motor is greater than zero and OFF when RPM reported by the motor is zero.
- External Status LED:  
Support for an external Status LED (10mA current-controlled driver), via a 2-pin MTA connector, for remote system status notification. The external Status LED operates in the same manner as the Onboard Status LED.
- Onboard Net LED:  
The Onboard Net LED is driven directly by the receive data signal. The NET LED shows all network traffic on a 2-wire network. The NET LED is intended to confirm low-level network connectivity, independent of microcontroller or firmware functionality. If A/B network wires are swapped, the NET LED will be normally on, providing quick diagnostics of this common condition.

Net LED Status Definition	
LED OFF	Power Lost or No Communications
LED Flickering	Network Data Traffic In Progress
LED ON	A/B network wires are swapped

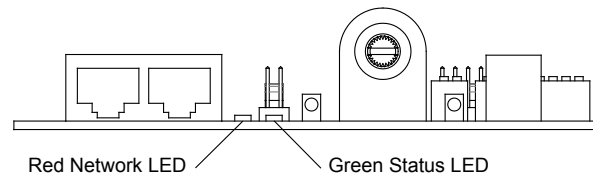

#### RJ45 Network Cable Connections:

1	2	3	4	5	6	7	8
Bus Power Pass Through	0V (GND)	RS-485				0V (GND)	Bus Power Pass Through
		+	NC	NC	-		

## Installation & Service Manual

### COMMUNICATION SPECIFICATIONS

#### Overview:

- MODBUS RTU protocol over RS485 (serial)
- 9600 baud rate, word length is 8, parity is none(n), stop bits=1
- 255 unique address values selectable by S2 switch settings (recommended network node capacity 200 nodes)
- Slew rate limited transceivers for improved network performance MODBUS Register Summary Table
- **DO NOT USE CROSSOVER CABLES. THIS MAY DAMAGE THE CONTROL CARD OR RENDER IT NON-OPERATIONAL.**

#### MODBUS Register Specifications:

Register	Name	R/W	Values & Defaults	Units	Origin	Comments
1	RUN/STOP	RW	0,1	1	RAM	power up from REG 14
2	DEMAND	RW	0-100	%	RAM	power up from REG 10
6	SPEED	R	0,5-2000	RPM	LIVE	
7	ANA1	R	0-1000	-	LIVE	Onboard Pot 0-1000=0-100%
9	STATUS	R	see detail	-	LIVE	
10	DEFAULT SPEED	RW	0-100	50	EEPROM	applies to network only
12	CURRENT SPEED	R	0-100	-	LIVE	
14	DEFAULT RUN/STOP	RW	0,1	1	EEPROM	applies in network mode only
24	ANA2	R	0-1000	-	LIVE	0-10V input 0-1000=0-10VDC

To reset non-volatile registers to factory default values, write 170 (AA hex) to Register 14, and then cycle power.

Note: Register 24 may be read in network mode to determine the value of 0-10VDC signal that *may* be connected. For example, a pressure transducer may be connected to indicate unit internal static pressure.

## ■ Troubleshooting

### **Mode Choice:**

Verify mode setting choice to DIP switch S1 (Control Mode), which is manual mode and then retry.

Net LED Status Definition	
Green LED OFF	Power Lost or No Communications
Green LED Flickering	Network Data Traffic In Progress
Green LED ON	A/B network wires are swapped

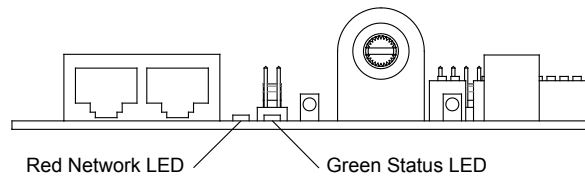

### **Motor Issues in Manual Mode:**

(If you are in a network or analog mode, contact your controls contractor for troubleshooting assistance; if you continue to need assistance, contact the factory.)

### **Unit is not adjustable:**

**Step 1.** Verify that rotation of the manual speed potentiometer does not change the RPM. If rotating does nothing, remove the electrical box cover, then remove the 4-pin motor connector from the control board and reinstall 180 degrees rotated. Also insure that the 4-pin connection wires are pushed down securely onto connector pins. Again adjust the knob to verify proper fan operation. Note: The 4 pin connector is on the 1/8" white cable from motor.

### **Low Air Velocity:**

- Step 1.** Check to be sure that the manual speed potentiometer is set correctly.
- Step 2.** Check incoming power supply for proper voltage (120,208-240,277/24).
- Step 3.** Examine the HEPA filter.

### **High Air Velocity:**

- Step 1.** Check to be sure that the air flow settings are correct.

### **Filter Issues:**

#### **Non-Laminar Flow and/or Excessive Contamination:**

- Step 1.** Insure that no large obstructions are upstream of airflow pattern.
- Step 2.** Determine that no other air-moving devices are operating in or around clean room which disrupt room's airflow pattern.
- Step 3.** Check air velocity and if low, conduct the "Low Air Velocity" procedure outlined above.

**If failure continues, contact ENVIRCO Technical Support at 800-884-0002.**

Installation & Service Manual

■ **Service: Removal and Replacement of Standard Filters**

**WARNING**  
DISCONNECT THE UNIT FROM THE ELECTRICAL POWER SOURCE BEFORE ATTEMPTING ANY SERVICE

**WARNING**  
THE STANDARD FILTER IS PROTECTED WITH AN EXPANDED METAL FACE SCREEN. THIS IS NEVER TO BE USED TO HANDLE THE FILTER. IT IS ONLY FOR PROTECTION AGAINST AN ACCIDENTAL TOUCH OF THE FILTER. ONLY HANDLE THE FILTER BY THE FRAME.

Note: All filters should be visually inspected for freight damage before installation. Since the filters are 4' x 4' in dimension it is necessary to use two workers when lifting the filter, and four workers for installation to avoid twisting or separation of the media seals. Handle the filter only by the frame and never place anything on the upstream filter side of the filter. Additionally, it is important to keep the filter level to prevent any shearing force on the media itself.

**For Standard Filters:**

Tools Required: Phillips Head Driver, Battery Operated Drill

**Step 1.** Remove the 28 plenum housing screws. Retain for installation of new filter.

**Step 2.** The plenum housing must be raised up and placed out of the way to allow the filter to be turned and lowered through the ceiling opening. Service wiring may need to be disconnected by qualified personnel.

**Step 3.** Before replacing with the new filter, carefully inspect the new filter for any visible damage. Also inspect the gasket and the T-Bar to insure a tight seal. Replace if necessary.

**Step 4.** To replace a filter, raise the filter and rotate into position in the ceiling grid (with power off), then lower the plenum housing into place. Reconnect wiring and hardware from previous steps that have been removed.

**Step 5.** Restore power and verify proper operation of FFU.

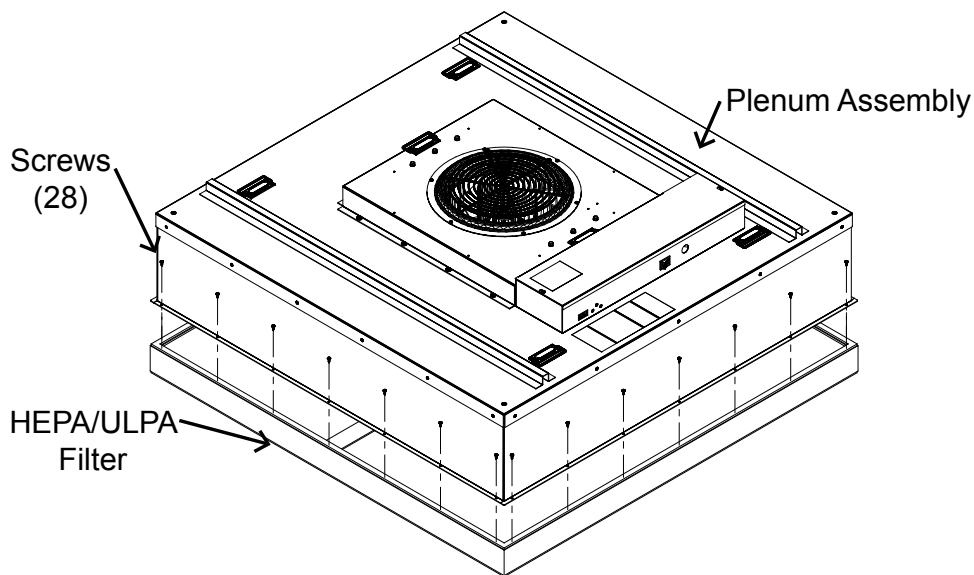

**Standard Filter Change**

### Installation & Service Manual

## ■ Service: Removal and Replacement of RSR/E Filters

### WARNING

DISCONNECT THE UNIT FROM THE ELECTRICAL POWER SOURCE BEFORE ATTEMPTING ANY SERVICE

### WARNING

THE STANDARD FILTER IS PROTECTED WITH AN EXPANDED METAL FACE SCREEN. THIS IS NEVER TO BE USED TO HANDLE THE FILTER. IT IS ONLY FOR PROTECTION AGAINST AN ACCIDENTAL TOUCH OF THE FILTER. ONLY HANDLE THE FILTER BY THE FRAME.

Note: All filters should be visually inspected for freight damage before installation. Since the filters are 4' x 4' in dimension it is necessary to use two workers when lifting the filter, and four workers for installation to avoid twisting or separation of the media seals. Handle the filter only by the frame and never place anything on the upstream filter side of the filter. Additionally, it is important to keep the filter level to prevent any shearing force on the media itself.

#### For RSR/E Filters:

Tools Required: Phillips Head Driver, Battery Operated Drill, 3/16" hex head ball driver (2ea)

**Step 1.** With the power off, remove the diffuser screen by removing the 6 each 10-32x1/2 screws, then carefully place in a safe location.

**Step 2.** Loosen the eight 1/4x20 socket head screws far enough to rotate the eight filter clips 90°. The filter may be loose enough to drop during this operation. If not, slowly pull the filter away from the knife-edge seal, taking care not to touch the filter face during this operation. It is important to pull the filter slowly away from the seal, so that the gel remains in the filter gel track.

**Step 3.** Carefully clean plenum assembly knife edge surface of residual gel material.

**Step 4.** Inspect filter for visible damage, if damaged set aside for replacement or repair.

**Step 5.** Inspect the gel seal, if reinstalling the removed filter. Determine if the gel has lost its ability to seal (i.e. the gel should reform to cover the track without voids or openings), if so repair the gel material or consider replacement of filter.

**Step 6.** Place the filter evenly against the filter-sealing surface of the RSR unit. Reposition filter clips and screws. The clips should be rotated and angled into place. It is recommended that four workers work on each corner of the filter simultaneously, holding the filter seated into the track. Hand tighten clips from opposite corners evenly until all clamps are tightened.

**Step 7.** Reinstall diffuser screen by hand-tightening the screws.

**Step 8.** Determine if recertification or testing of replacement is required.

**Step 9:** Restore power to FFU and verify proper operation of FFU.

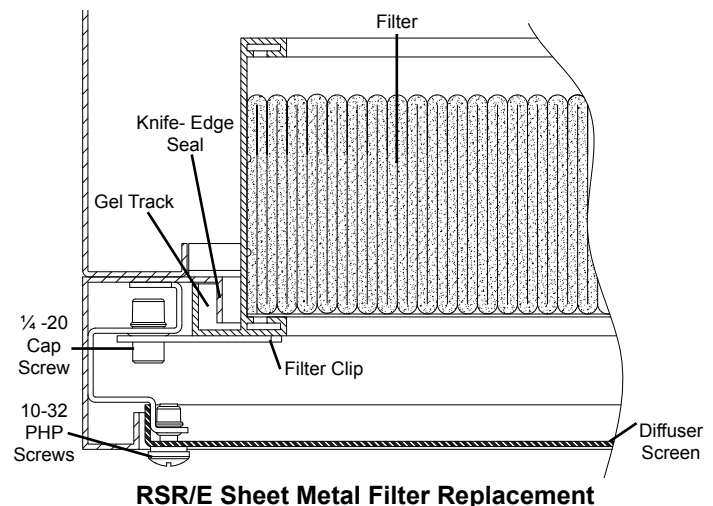
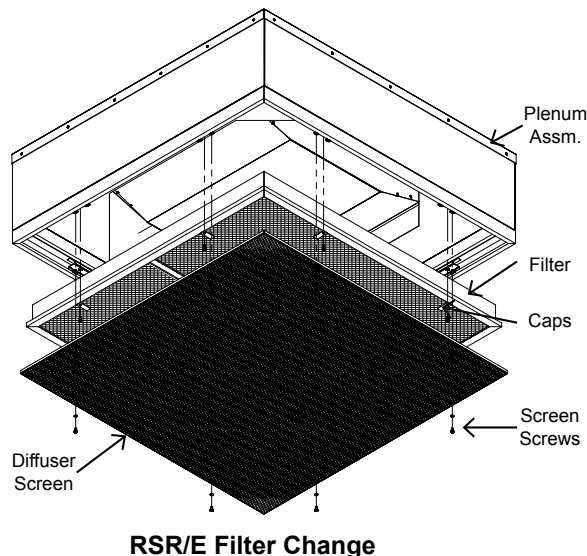

Installation & Service Manual

■ **Service: Standard and RSR Motor Removal and Installation**

**WARNING**

DISCONNECT THE UNIT FROM THE ELECTRICAL POWER SOURCE BEFORE ATTEMPTING ANY SERVICE

**WARNING**

ELECTRICAL SERVICE SHOULD ONLY BE PERFORMED BY A LICENSED OR QUALIFIED ELECTRICIAN.

Tools Required: Phillips Head Driver, Battery Operated Drill, (2) 8" adjustable wrenches, 10 mm hex head wrench, #2 screwdriver, and slip joint pliers

**Step 1.** To gain access to the motor, remove the ceiling panel next to the unit, if applicable.

**Step 2.** Switch the ON-OFF switch to the off position.

**Step 3.** Loosen the electrical box cover screws (2), and slide/lift off cover.

**Step 4.** Make note of all wire routing and locations for later reinstallation.

**Step 5.** Disconnect 4-pin and 5-pin wire harnesses from the electrical box housing and remove the tubing for test port, if installed.

**Step 6.** Remove the twelve mounting screws to free the motor/blower assembly from the lid assembly. If using power drivers, set the unit to a low torque setting to avoid stripping the sheet metal screws. Carefully remove housing assembly, paying attention to wire routing.

**Step 7.** Unwire the control cap by removing the cap cover and unplugging the cable connector to the motor from inside, then pull back through the grommet next to the motor. Rubber grommet will need to be removed for connection clearance.

**Step 8.** Remove the six 10 mm bolts from the motor mounting plate to motor housing assembly.

**Step 9.** Using one adjustable wrench, loosen the hex nut that attach the blower wheel to the motor shaft while holding motor shaft still with the second wrench. Remove blower wheel from motor shaft and the c-clip for reuse with new motor.

**Step 10.** Remove the motor mounting hardware from the backside of the motor mounting plate. Replace with the new motor and reassemble by reversing the above order.

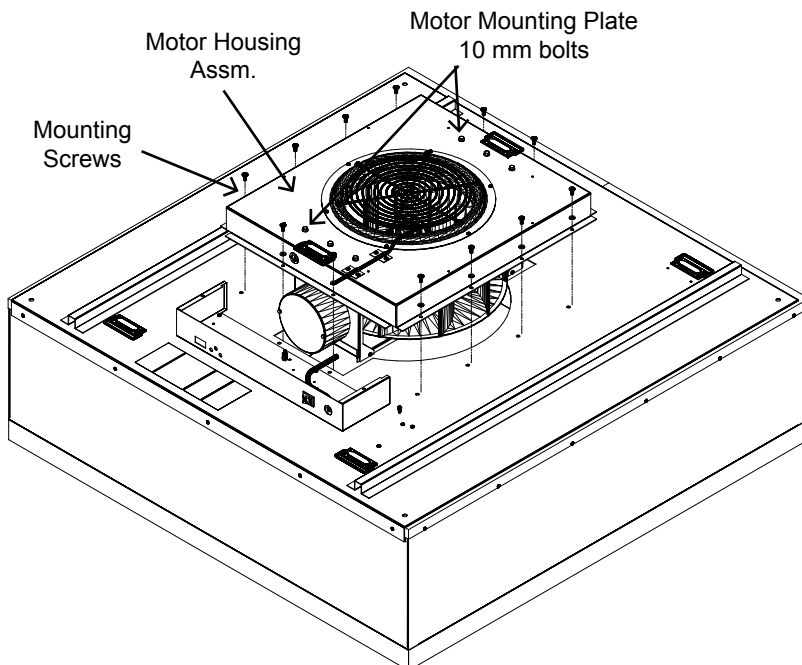

**Motor/Electrical Removal**

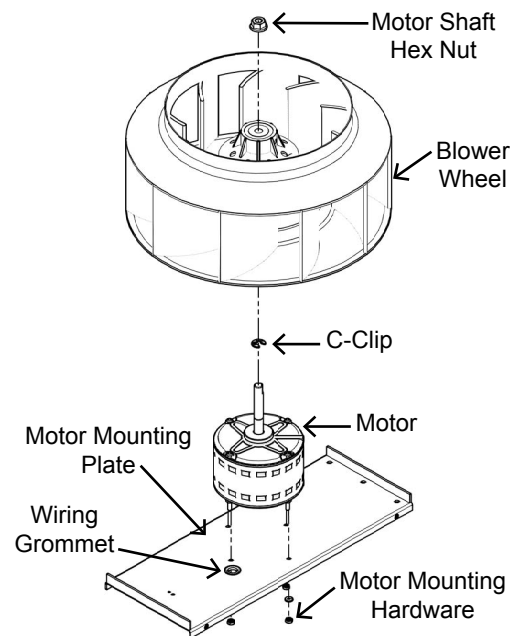

**Motor Assembly**

### Installation & Service Manual

## ■ Service: RSR/E Motor Removal and Installation

### WARNING

DISCONNECT THE UNIT FROM THE ELECTRICAL POWER SOURCE BEFORE ATTEMPTING ANY SERVICE

### WARNING

ELECTRICAL SERVICE SHOULD ONLY BE PERFORMED BY A LICENSED OR QUALIFIED ELECTRICIAN.

### Note: Minimum 2 person project.

Tools Required: 3/16 Ball Driver, Phillips screw bit, Head Driver, Battery Operated Drill, (2) 8" adjustable wrenches, 10 mm hex head wrench, #2 standard screwdriver, and slip joint pliers

**Step 1.** Diffuser Screen Removal.

**Step 2.** HEPA Filter Removal.

**Step 3.** Remove (10) baffle mounting screws, carefully remove baffle.

**Step 4.** Disconnect the 4-pin and 5-pin control cables at the cap.

**Step 5.** Remove cover of cap to access motor cable for disconnection and routing back to motor - two screws for cap cover/ mounting of cap have nuts needing to be re-used.

**Step 6.** At the motor mounting plate, remove the (4) gusset screws at the corners, then the (6) bolts of the lower blower assembly.

**Step 7.** Remove blower wheel using (2) adjustable wrenches, one to hold motor shaft and the other to loosen the 3/4" hex nut. Once wheel is removed, then using screwdriver, pull c-clip from motor shaft.

**Step 8.** Carefully route motor wire through grommet hole after removing rubber grommet to allow for cable connection and clearance.

**Step 9.** Remove hex nuts and washers from (4) mounting studs of motor to separate motor from plate.

**Step 10.** Install new motor and components in reverse order.

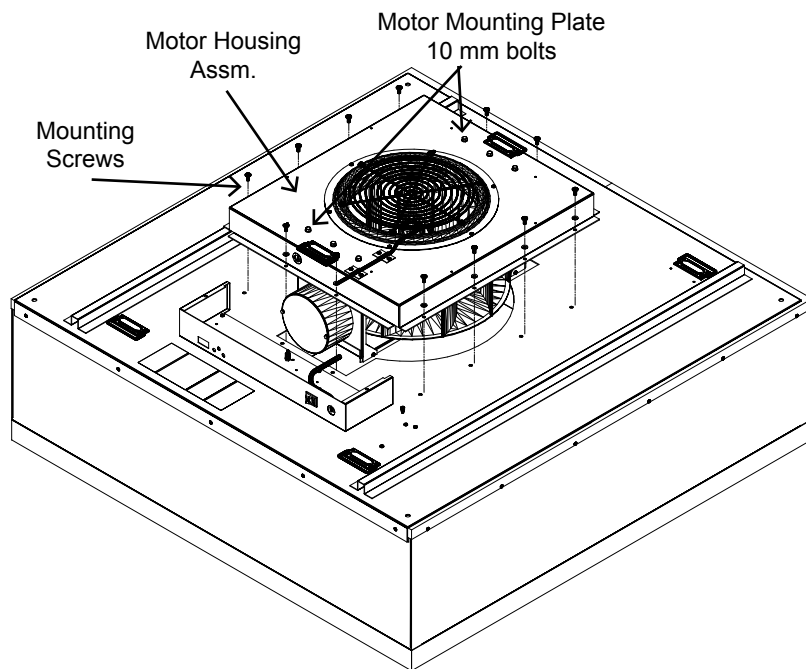

**Motor/Electrical Removal**

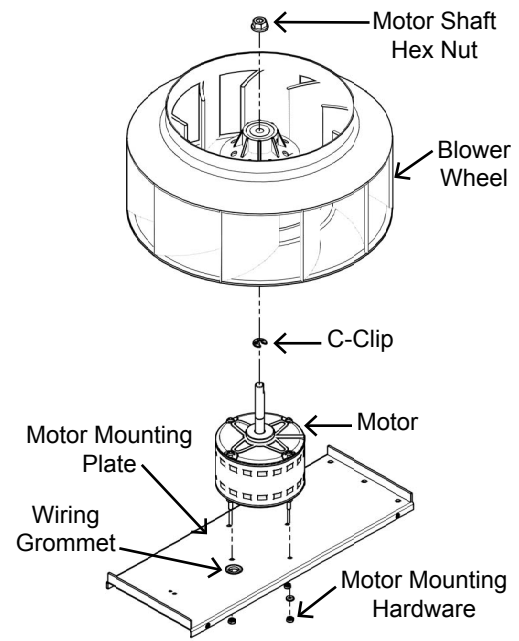

**Motor Assembly**



Installation & Service Manual

■ **Wiring Diagrams**

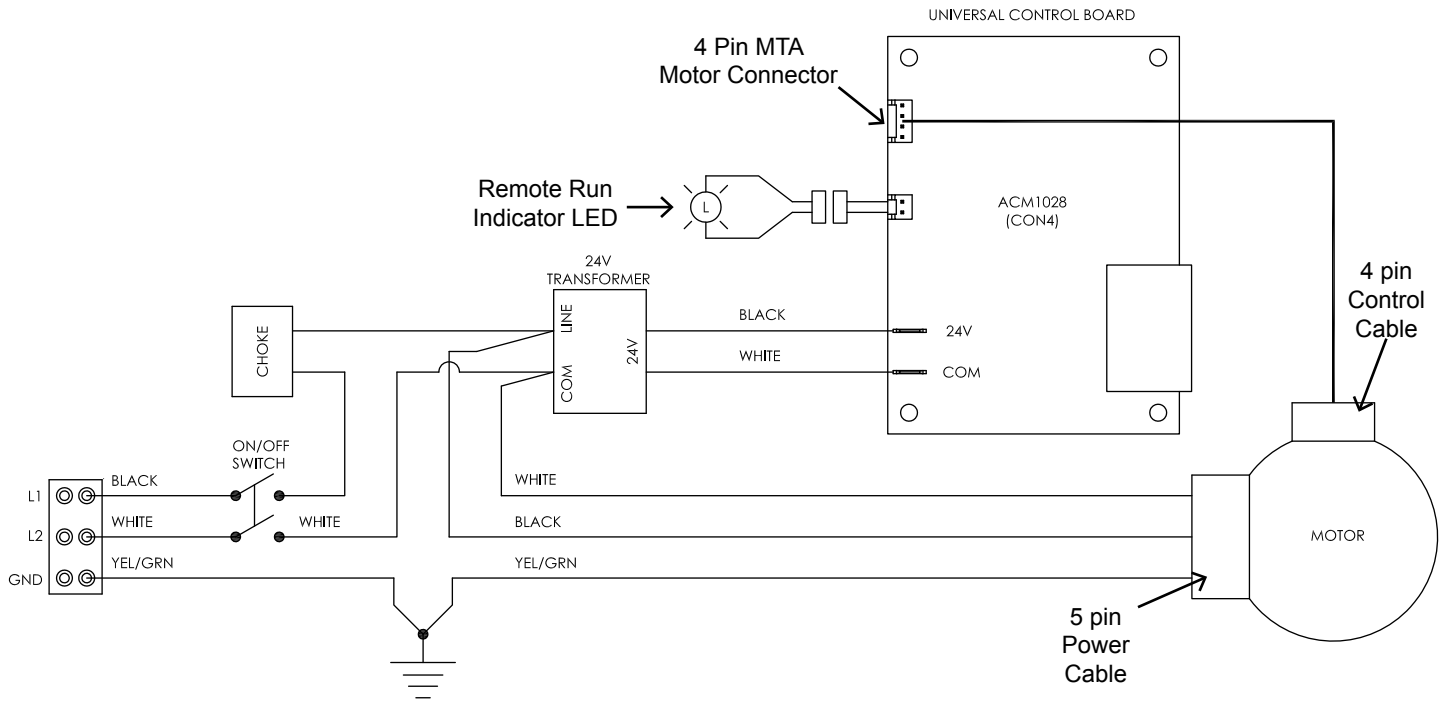

**Universal Card Wiring Diagram**

#### ■ Replacement Parts List

MAC 10 4x4 Parts	Part Number
Grommet	63388
Motor - 120/240/277 ECM w/ Program	24397-025
Choke 5.5 amps	64103
Transformer 120/24 volts	63667
Transformer 220/24 volts	63666
Transformer 277/24 volts	63665
Venturi ring	64115
Blower Wheel Poly	63825
Universal Control Card	265888
Pressure Switch	63415-001
Filter HEPA Standard 47.63 x 47.63 White Painted Metal Screen	69575-004
Filter RSR/RSRE 45 x 45 x 3 HEPA	69604-001H
Filter RSR/RSRE 45 x 45 x 3 ULPA	69604-001U
Rocker Switch	63739-002
Finger Guard	63576-003
RSR-Filter Clip (RSR)	38205-001
Screw 1/4-20x1/2 (RSR)	63152
Washer Flat Nylon .20 ID	120456-005
Eyebolts	222449-001
Diffuser Screen Aluminum	842732-001

Note: Verify filter size by contacting factory (see page 3).

## Installation & Service Manual

### ■ Limited Warranty

LIMITED WARRANTY: Unless otherwise expressly stated in ENVIRCO's published specifications for the Goods, ENVIRCO warrants that Goods are free from defects in material and workmanship, except for services which are warranted to be performed in a competent and diligent manner in accordance with any mutually agreed specifications. The foregoing warranty shall apply for eighteen (18) months from the date of shipment from ENVIRCO's facility, except for services for which the warranty shall apply for ninety (90) days from the date of performance (the "Warranty Period"). Provided Buyer informs ENVIRCO in writing of any breach of warranty prior to the expiration of the applicable Warranty Period, ENVIRCO shall, as its sole obligation and Buyer's sole and exclusive remedy for any breach of this warranty, repair or replace/re-perform the Goods which gave rise to the breach or, at ENVIRCO's option, refund the amounts paid by Buyer for the Goods which gave rise to the breach. Any repair, replacement or re-performance by ENVIRCO hereunder shall not extend the applicable Warranty Period. The parties shall mutually agree on the specifications of any test to determine the presence of a defect. Unless otherwise agreed upon by ENVIRCO in writing, Buyer shall bear the costs of access, de-installation, re-installation and transportation of Goods to ENVIRCO and back to Buyer. These warranties and remedies are conditioned upon (a) the proper storage, installation, operation, and maintenance of the Goods and conformance with the proper operation instruction manuals provided by ENVIRCO or its suppliers or subcontractors, (b) Buyer keeping proper records of operation and maintenance during the applicable Warranty Period and providing ENVIRCO access to those records, and (c) modification or repair of the Goods only as authorized by ENVIRCO. ENVIRCO does not warrant the Goods or any repaired or replacement parts against normal wear and tear or damage caused by misuse, accident, or use against the instructions of ENVIRCO. Any modification or repair of any of the Goods not authorized by ENVIRCO shall render the warranty null and void. EXCEPT AS EXPRESSLY SET FORTH HEREIN, ENVIRCO MAKES NO OTHER WARRANTIES, EXPRESS OR IMPLIED, INCLUDING, BUT NOT LIMITED TO, ANY IMPLIED WARRANTIES OF MERCHANTABILITY, NON-INFRINGEMENT OR FITNESS FOR A PARTICULAR PURPOSE WHICH ARE HEREBY DISCLAIMED TO THE EXTENT PERMITTED BY APPLICABLE LAW.

### ■ Testing

Each MAC 10 LEDC filter unit is thoroughly tested at the factory before shipment. However, because of the "rigors" of shipping, ENVIRCO encourages its re-test after installation.

ENVIRCO recommends that the customer contact an independent organization, with technicians trained and experienced in performance evaluation and maintenance of clean air equipment.

HEPA filters (Type J) are tested to IEST-RP-00034. ULPA filters are tested to (Type F) IEST-RP-00034. All filters are UL 900 recognized. Your filters may have special requirements, please see original engineering specifications for your specific project.

All units that are airflow tested at ENVIRCO are tested using a Shortridge Airdata Multimeter 870 with a Velgrid head. The recommended method of reading is to place one corner of the Velgrid head 1-1/4" from the corner of the filter face and then take four readings evenly spaced along the four foot side, then repeat these reads three additional times. This gives a total of 16 readings to test the unit. All advertised data is based on using the Velgrid with 16 readings (256 velocity points). ENVIRCO recognized the using 16 readings during a cleanroom start-up may be time consuming and recommends using 4 Velgrid readings taken on each 2x2 filter section will approximate the same as 16 readings.

Additional independent testing on the ENVIRCO Mac 10 4x4 shows that using two-2x4 hoods simultaneously give airflow data (cfm) with 5 percent of a duct traverse using 10 diameters of straight duct upstream of the fan intake.

# Clean air solutions built for you.

MORE INFORMATION AVAILABLE AT [WWW.ENVIRCO.COM](http://WWW.ENVIRCO.COM)

## Industrial

### Cleanroom Products

- » MAC 10<sup>®</sup> Original
- » MAC 10<sup>®</sup> IQ™
- » MAC 10<sup>®</sup> IQ™ LAF
- » MAC 10<sup>®</sup> LEAC™
- » MAC 10<sup>®</sup> LEAC2™
- » MAC 10<sup>®</sup> LEDC™
- » Ducted Ceiling Module:  
DCM & RSR
- » AC or DC Control Systems
- » MAC-T Ceiling Grid System

## Hospital & Healthcare

### Hospital & Healthcare

- » IsoClean<sup>®</sup> and IsoClean  
with Ultraviolet Light
- » AirCeil<sup>®</sup>
- » Hospi-Gard<sup>®</sup> Room  
Pressure Monitor

### Enviramedic Products

- » HOR Horizontal Flow  
Enclosure
- » HCF Horizontal Flow  
Surgery Room
- » VOR Vertical Flow Surgery  
Isolator

## Pharmaceutical

### Pharmaceutical & Medical Device

- » Unimodule M2 Vertical  
Laminar Flow Workstation
- » METD 100% Exhausted  
Vertical Flow Workstation
- » Laminar Downflow Module

## Laboratory & Research

### Laboratory & Research

- » 100-Plus Horizontal or  
Vertical Flow Clean Bench
- » Unidirectional Flow  
Horizontal Flow Bench (LF)
- » TT Table Top Horizontal  
Flow Clean Bench
- » EnviraLab Sterility Module:  
ESM

ENVIRCO MAC 10 is a registered trademark of ENVIRCO, USA. Specifications subject to modifications or changes without notice. US patents 4,560,395 and 5,470,363. Other patents issued and pending in foreign countries.



**ENVIRCO**<sup>®</sup>

101 McNeill Road | Sanford, NC 27330, USA

tel: 919.775.2201 | toll free: 800.884.0002 | fax: 800.458.2379

[www.envirco.com](http://www.envirco.com) | email: [info@envirco.com](mailto:info@envirco.com)