

PRODUCT DATA SHEET

■ Infrared Hand-held Control Option MAC10 LEDC and MAC10 IQ

The ECM-Infrared Remote Control System provides a means to remotely adjust the output of ECM Motor. These are fractional horsepower fan motors featuring an internal microprocessor to provide exceptional efficiency, performance and motor life. Using the equipment manufacturer's fan curve, the motor maintains a constant airflow. The ECM-IRC allows adjustment of the airflow between the manufacturer's programmed minimum and maximum airflow. Adjustment is achieved by setting an airflow index from 1-100 into the control.

A handheld remote control sends modulated infrared signals to a receiver on the control. The control may be mounted on or near the equipment.

A flow index lamp flashes out the motor's output, so instruments are not required to adjust or record the air balance setting. A red status lamp indicates the motor is powered and turning.

Lamps and the infrared sensor may be mounted on the control, or remoted to accommodate a wide variety of equipment configurations.



■ Operation

The IR sensor is mounted near the red status lamp. Point the remote at the target (red lamp if the motor is on) on the equipment. Operate the On/Off button or any of the four ↑/↓ buttons. The green lamp near the target lights, indicating you are in an adjustment session. Continue to operate the on/off button or any of the four ↑/↓ buttons to achieve the desired settings. Press the Enter button to save your new settings and exit the adjustment session. Press the Clear button to delete your new settings, revert to the original settings and exit the adjustment session. If you enter an adjustment session and do not make any adjustments for 15 minutes, the adjustment session automatically clears. Use the Clear button to read the current settings. Point the remote at the target and press the Clear button.

A green lamp begins to flash indicating the signal was received. The flash sequence indicates the current flow index. The sequence occurs in two sets. The tens (1st) set uses long flashes to indicate the tens digit. The units (2nd) set uses short flashes to indicate the units digit. An extra long flash in the tens set or the units set indicates the value of the corresponding digit is zero.

Use the On/Off button to turn the motor on or off. Point the remote at the target on the equipment and press the on/off button. If you press Enter while the motor is off, the motor stays off, even through a power on/off cycle.

Adjust the flow index using the ↑/↓ buttons. The ↑/↓ button pair on the left adjusts the index ↑/↓ 10. The ↑/↓ button pair on the right adjusts the flow index ↑/↓ 1. Using the ↑/↓ 10 pair, you can quickly move the index up and down. Using the ↑/↓ 1 pair, you can precisely set the index to achieve the desired flow. During an adjustment session, the green lamp blinks each time you make a valid entry. If the flow index is already 100, and you try to increase the flow index, the green lamp does not blink, and the increase does not occur. If the flow index is at 91 and you press the ↑10 button, the green lamp does not blink and the increase does not occur because your entry would take the index above 100. When the flow index is greater than 90, use the ↑1 button to increase the index. The ↓1 and ↓10 keys respond in a like manner when you try to set the flow index below 1. (Zero is not a valid flow index).

PRODUCT DATA SHEET

■ Specifications

Power NEC Class II Only
 24 Vac ± 20% 50/60 Hz
 2 W, 4 VA + 1VA/Motor
 2 motors per control max.

Outputs Go & Vspd
 24 Vdc @ 20 mA

Signal Supports ECM Autoswitch Function

Thermal Stability >0.01%/oF

Operating Environment 0oF to 130 o (-18oC to 55oC)
 10-80% rh
Power Connections 1/4 Tabs
 Or
 5 terminal screw termination (T option)

Cable 22 AWG, 4 Conductor

■ Ordering

Infrared Remote Control EVO™/ECM-IRC _ _ _
 Infrared Handheld Remote EVO™/IRC-Remote

Add an “en” suffix for the remote lamps/IR sensor.
 Add a “T” suffix for terminal strip.

■ Wiring

Power the EVO™/ECM-IRC control with a 24 Vac NEC Class II power source. Observe all code requirements regarding Class II circuits to insure a safe, reliable installation. Connect the neutral connection to the grounded side of the 24 Vac Class II power source as required by code. Connect the 24Vac 50/60Hz connection to the hot side of the 24 Vac Class II power source. The control circuit design may interrupt the hot side power source as a means to stop the ECM Motor. The control cable is fitted with a 16 pin keyed connector. Fit this connector into the mating socket on the ECM Motor. The other end is fitted with a 4-pin connector. Fit this connector into the mating socket on the edge of the EVO™/ECM-IRC controller. Plug the connector in with the cable exiting away from the board. Be sure you are lined up with the socket before pushing in the connector.

■ Testing

The EVO™/ECM-IRC controller provides a “GO” signal and a “Vspd” signal to the ECM Motor™. The “GO” signal is simple, while the Vspd signal is complex. Both may be tested with a DC voltmeter. Make sure the AC power is between 18 and 25 Vac. Set the DC voltmeter to measure 25 Vdc. With the motor & controller powered and connected:

Measure the voltage between GREEN pin 3 (negative) and WHITE pin 15 (GO signal) of the ECM Motor connector. It should be at least 9 Vdc. It may be as high as 25 Vdc, depending on the length of the control wire and the number of connected motors.

■ Mounting

Wire as shown for remote mounting Mount the control inside a metal junction box, control cabinet or enclosure. Make mounting, lamp and IR sensor holes through the cover or enclosure wall and mount the control to the inside. A standard electrical wall plate may be used as a mounting plate, or mounting template.

The ECM Cable is factory fitted with a connector at each end. The end connecting to the controller may be pulled through an empty 3/4” conduit. Mount the controller with clearance for the 24 Vac power wires and control cable connector. Remote mount the control in a single gang electrical switchbox. Use a standard switch cover to cover the unit.

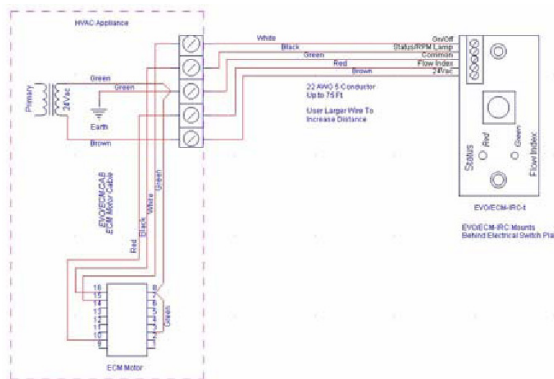

■ IR Sensor Components

63760 IR, Hand-held Control
 63758 IR, Hand-held Controller, w/o Sensor
 63759-005 IR Sensor Harness