

MAC-T Ceiling Grid System
2" Heavy Duty for Cleanroom
OPERATION & MAINTENANCE MANUAL

Table of Contents

Introduction.....	3
Tools	3
Uncrating, Inspection, and Inventory	3
Notes	3
Part Numbers & Extrusion Guide Description	4
Diagram	5
Installation	6
Maintenance.....	7
Warranty	7

Please read through instructions before beginning installation.

Installation & Service Manual

■ Introduction

ENVIRCO offers the T-Grid 2" Gasket Seal Grid Cleanroom Ceiling System with superior materials that provides a structural grid system and zinc alloy die-castings. The materials are packaged with care, but check for damage that may have occurred during transit. Please inspect the shipment and quantity before beginning installation. Please notify us promptly if you experience any problems at 800.884.0002.

The following information is provided by ENVIRCO as a general guideline for the installation of the 2" T-Grid cleanroom ceiling grid system. This information should be reviewed prior to commencing installation. The intent is to be as specific as possible in detail for a typical project, yet general enough to be utilized by most installations. It is ENVIRCO's intent that the descriptions are helpful and easy to understand. If there are any questions, comments, or special considerations, please contact ENVIRCO Technical Support at 800.884.0002.

Note: This narrative assumes that the job-site is clear and ready for the construction of cleanroom ceiling.

■ Tools

It is suggested that the following tools be used to erect this system:

- Laser or Suitable Leveling Instrument
- Phillips head Drive & Cordless Drill
- Circular Saw with Fine Toothed Carbide Tip Blade
(triple toothed, negative rake, aluminum blade)
- Miter Saw with Fine Toothed Carbide Tip Blade
(triple toothed, negative rake, aluminum blade)

■ Uncrating, Inspection, and Inventory

The ENVIRCO ceiling system is packaged in the factory in a manner to protect each part during normal shipping and handling. It is recommended by ENVIRCO that the original packaging remain intact as much as possible until the individual parts are needed. All extrusion components are packaged in boxes with protective paper between finished surfaces.

As the skids are received at the job-site, they should be placed in a location near the installation area, where they will not become an obstacle, or require to be moved at a later time. The skids should then be opened, however leaving the internal packaging unchanged. Pieces should be removed on an as needed basis and the packaging discarded. At this time, however, the components should be visually inspected for obvious damage and an inventory taken to confirm that all parts are received in good condition. Notify ENVIRCO immediately of any discrepancies in quantity.

■ Fasteners Not Provided by ENVIRCO

ENVIRCO does not provide the attachment hardware for the existing structure or framework. All hardware required from the turnbuckle to the existing support structure is not provided.

■ Special Notes

Due to expansion and contraction properties of aluminum, it is recommended that this system be installed in a temperature that is as close as possible to that which the finished room will operate. Stock T-bar or wall angle with a length of over 4 feet is cut with a tolerance of $\pm .032"$. Stock cross-tees less than 4 feet is cut to $\pm .016"$. The above stated tolerances are measured at a material temperature of from 60 to 90 F. All field cuts including perimeter miter cuts are to be performed by the installing contractor.

MAC-T Ceiling Grid System

2" Heavy Duty for Cleanroom



Installation & Service Manual

■ Part Numbers and Extrusion Guide

Identify various parts from reference drawings on Page 5.

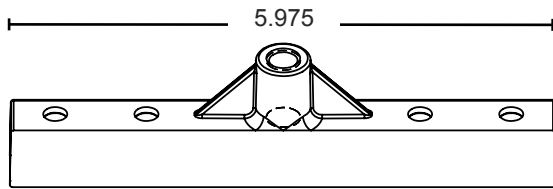

P/N: 267324-007

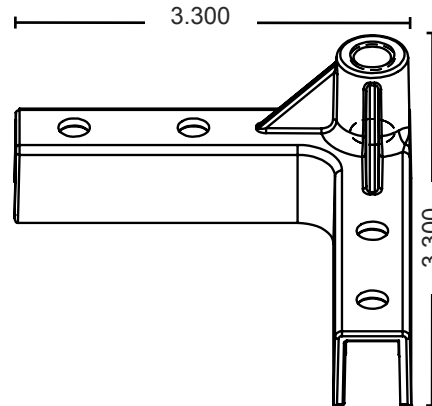

P/N: 267324-008

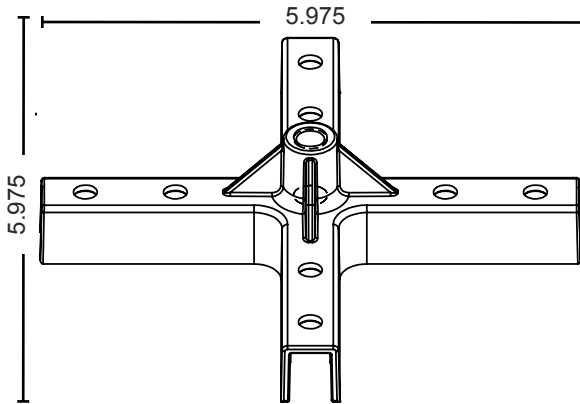

P/N: 267324-001

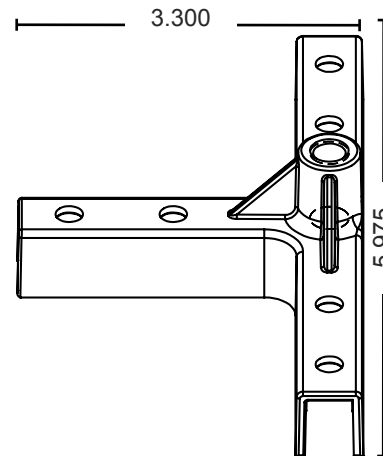

P/N: 267324-002

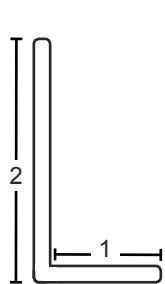

P/N: 267322-007

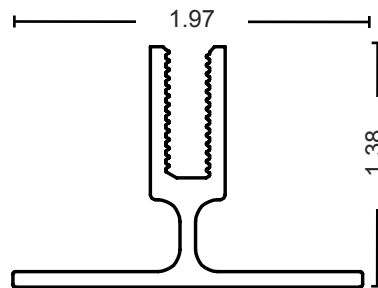

P/N: 267322-001

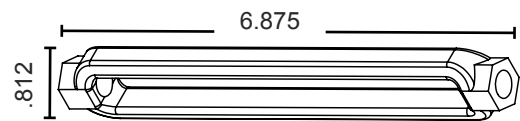

P/N: 267324-003

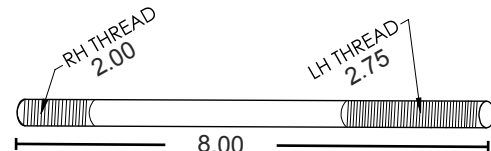

P/N: 267324-004

Installation & Service Manual

■ Diagram

#	P/N	Description
MAC 10 T-GRID COMPONENTS		
1	267322-001	MT240-Main Runner 20ft
1	267322-012	MT240-Main Runner 20ft (anodized aluminum)
1	267322-011	MT144-Main Runner 12ft
1	267322-013	MT144-Main Runner 12ft (anodized aluminum)
1	267322-002	MT120-Main Runner 10ft
1	267322-014	MT120-Main Runner 10ft (anodized aluminum)
1	267322-003	MT96-Main Runner 8ft
1	267322-015	MT96-Main Runner 8ft (anodized aluminum)
1	267322-004	MT72-Main Runner 6ft
1	267322-016	MT72-Main Runner 6ft (anodized aluminum)
2	267322-005	CT46.5 Cross Tee 46.5"
2	267322-017	CT46.5 Cross Tee 46.5" (anodized aluminum)
2	267322-006	CG22.5 Cross Tee 22.5"
2	267322-018	CG22.5 Cross Tee 22.5" (anodized aluminum)
2	267322-007	1 X 2 Wall Angle 10ft
2	267322-019	1 X 2 Wall Angle 10ft (anodized aluminum)
2	267322-008	1 X 2 Wall Angle 20ft
2	267322-020	1 X 2 Wall Angle 20ft (anodized aluminum)
NS	267322-009	Gasket TGC 50ft
2	267322-010	Main Splice TGC (12ft)
MAC 10 T-GRID HARDWARE - CONNECTIONS		
3	267324-001	Cast 4 Way Connector
3	267324-002	Cast 3 Way Connector
4	267324-003	Turnbuckle 3/8-16x7
5	267324-004	Rod, 16 Thread x 3/8" X 8"
6	267324-005	Screw 1/4-20x3/4 Phms
7	267324-006	Nut 3/8-16 Hex
3	267324-007	Cast 2 Way Connector
NS	267324-008	Corner Cast 2 Way
NS	267324-009	Eyebolt with Nut 3/8"
NS	267324-010	3/8 Rod Tek
NS	267324-011	12 Gauge Wire Hangers
MAC 10 T-GRID HARDWARE - LIGHTING		
NS	267325-001	120v Light 2x4 T-bar, 4 Tube
NS	267325-002	230v Light 2x4 T-bar, 4 Tube
NS	267325-003	277v Light 2x4 T-bar, 4 Tube
NS	267325-004	120v Light 1x4 Surface, 2 Tube
NS	267325-005	230v Light 1x4 Surface, 2 Tube
NS	267325-006	277v Light 1x4 Surface, 2 Tube

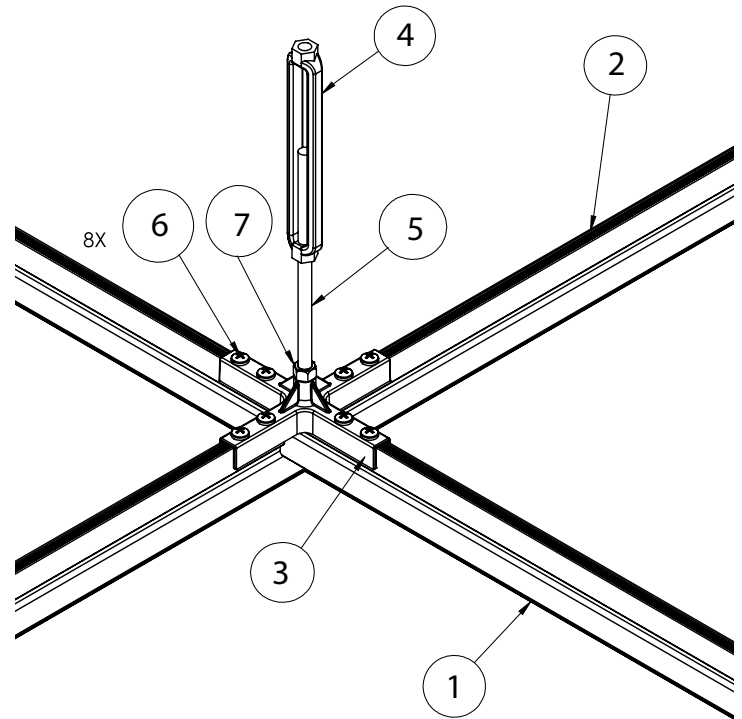

NS=Not Shown

Installation & Service Manual

■ Installation of Wall Angle

The first component to be installed is the wall angle. Attach lengths of wall angle to walls using appropriate fasteners for the type of existing wall. It is advisable to pick one wall as a starting point and begin attaching wall angle from the center of the wall towards the corners. A laser or other suitable leveling tool should be used to assure a consistently level finished product.

Continue attaching wall angle around walls and columns, if any, until complete. The wall angle sections are connected at the intersections with appropriate fastener into the existing wall.

■ Wall Angle at Corners

The wall angle is to be cut using a miter saw (with the proper cutting blade) at 45 degrees in the field by the installation team to create corners.

■ Installation of T-Bar

Once the wall angle is installed, the rest of the grid installation can begin. The extruded aluminum sections are connected at the intersections with the 4-way zinc alloy die castings. The bottom of this casting has an open face channel that embraces the top extruded screw boss of the main runners and cross bar sections. The castings are bolted to the extrusion with 1/4-20 x 3/4" full threaded Phillips head cap screws. This is most easily done with a power drill or other such tool. The grid is suspended with 3/8"-16 threaded rod for which the castings are already tapped.

The castings will accept a special right hand/left hand (RH-LH) threaded rod to allow for use with turnbuckles. The RH-LH threaded rod should be turned into the casting and "bottom out" on the main runner. Turnbuckles are not a requirement for secure suspension. However, in that case, some other means of leveling the grid system should be used.

Hang all of the threaded rods, turnbuckles and castings at the appropriate 2' x 4' or 4' x 4' centers (nominal) and then bolt main runners (12') lengths into place. The cross tees may then be bolted in using a 24 1/2" x 48 1/2" on center configuration. (This may vary depending on your grid layout).

■ Installation of Gasket

The gasket should come factory applied. If it does not, perform the following. The ENVIRCO system provides 1/8" x 3/8" gasket tape is usually applied to the extruded grid members prior to installation. After unpacking the part, the surface of the extrusion is cleaned using a solution of isopropyl alcohol and water. The gasket tape is then applied with the adhesive side down, leaving approximately 3/4" to 1" extra gasket material on each end of the cross tees to allow for a proper seal of the gaskets at the grid intersection.

Installation & Service Manual

■ Installation of Light and Filter Fixtures

Once the ceiling grid is installed, the fixture installation can begin. If "lay-in" light fixtures are to be used, they should be installed first in order to make the wiring easier. Once the light fixtures are in place and wired, the filter modules can be installed. This is done by pushing the filter fixture through the grid at an angle and then lowering them until they nest in place. After all the filter modules are in place, the blank ceiling panels are installed. Installation of Ceiling Tiles Blank panels are placed in the grid opening after the gasket is in place. Special cuts can be made by measuring from the center line of the grid and deducting 7/8" from that dimension, (see chart below). For example, a 24 1/2" x 48 1/2" grid centerline would take a blank 23 5/8" x 47 5/8" in size. If the blank panel hold down clips are utilized, a minimum of six (6) clips per 2' x 4' blank panel are required. The clips are secured to the T-Grid extrusions utilizing a 1/4"-20 bolt.

Center Line of Grid - 24 1/2" x 48 1/2"

Module, Fixture, and Ceiling Tile Size - 23 5/8" x 47 5/8"

CAUTION: Be extremely careful when installing HEPA filters. Be careful not to touch the face of the filter (bottom of the fixture). This can cause damage to the HEPA filter unit and may need replacing.

■ Sealing Wall Angle

This is a simple process utilizing an approved construction sealant. A bead of sealant is placed at the corner of the wall angle and existing wall on the room side. The sealant should be applied to assure an airtight seal.

■ Maintenance

Prior to completing the installation, a final inspection and wipe-down should take place. Wipe the panels and extrusions with an approved cleanroom alcohol wipe. If any chemicals are to be utilized, spot check with extra materials prior to use to insure that the finish of the wall system is not damaged.

Cleaning of the ENVIRCO MAC-T Ceiling Grid requires the use of non-shedding, cleanroom approved wipers and a solvent of isopropyl alcohol diluted with distilled water.

■ Warranty

ENVIRCO Corporation ("ENVIRCO") warrants the equipment will be free of defects in materials and workmanship under normal use for a period of one (1) year. ENVIRCO's sole obligation under this warranty is to repair or replace any parts of the equipment which are defective for a period of one (1) year from the invoice date, provided that the repair or replacement is actually performed within the one (1) year period from the invoice date. The Buyer agrees to assume any incidental expenses including but not limited to the cost of transporting the defective equipment to ENVIRCO's repair facility. The Buyer's sole remedy under this limited warranty is the repair or replacement of any defective part of the equipment.

ENVIRCO disclaims any implied warranties including warranties of merchantability and fitness for a particular purpose. In no event shall ENVIRCO be liable for punitive, incidental, or consequential damages arising out of this sale, including, but not limited to damage to a person or property, loss of use, loss of time, inconvenience, equipment rental, loss of earnings or profit or any other commercial loss. This warranty excludes certain expendable items such as light tubes, prefilters, etc. ENVIRCO expressly disclaims and excludes from the warranty any responsibility for equipment failures and/or defects attributable to improper maintenance, abuse, accident or modification of equipment (such as application of an adjustable frequency drive).

Clean air solutions built for you.

MORE INFORMATION AVAILABLE AT WWW.ENVIRCO.COM

Industrial

Cleanroom Products

- » MAC 10[®] Original
- » MAC 10[®] IQ™
- » MAC 10[®] IQ™ LAF
- » MAC 10[®] LEAC™
- » MAC 10[®] LEAC2™
- » MAC 10[®] LEDC™
- » Ducted Ceiling Module:
DCM & RSR
- » AC or DC Control Systems
- » MAC-T Ceiling Grid System

Hospital & Healthcare

Hospital & Healthcare

- » IsoClean[®] and IsoClean
with Ultraviolet Light
- » AirCeil[®]
- » Hospi-Gard[®] Room
Pressure Monitor

Enviramedic Products

- » HOR Horizontal Flow
Enclosure
- » HCF Horizontal Flow
Surgery Room
- » VOR Vertical Flow Surgery
Isolator

Pharmaceutical

Pharmaceutical & Medical Device

- » Unimodule M2 Vertical
Laminar Flow Workstation
- » METD 100% Exhausted
Vertical Flow Workstation
- » Laminar Downflow Module

Laboratory & Research

Laboratory & Research

- » 100-Plus Horizontal or
Vertical Flow Clean Bench
- » Unidirectional Flow
Horizontal Flow Bench (LF)
- » TT Table Top Horizontal
Flow Clean Bench
- » EnviraLab Sterility Module:
ESM

ENVIRCO MAC 10 is a registered trademark of ENVIRCO, USA. Specifications subject to modifications or changes without notice. US patents 4,560,395 and 5,470,363. Other patents issued and pending in foreign countries.



ENVIRCO[®]

101 McNeill Road | Sanford, NC 27330, USA

tel: 919.775.2201 | toll free: 800.884.0002 | fax: 800.458.2379

www.envirco.com | email: info@envirco.com