

HOUSING STYLE:

- RSR - FILTER ONLY ROOMSIDE REMOVABLE
- RSRE - FILTER, BAFFLE, AND MOTOR ROOMSIDE REMOVABLE

MOTOR: ECM MOTOR / FORWARD CURVE BLOWER

- 120V, 60 Hz, 1 PHASE, 2.3 FLA
- 208-240V, 50/60 Hz, 1 PHASE, 1.5 FLA
- 277V, 60 Hz, 1 PHASE, 1.3 FLA

FILTER:

- HEPA 99.99% @ 0.3 MICRON UL 900 (STANDARD)
- OTHER _____

CONTROL:

- UNIVERSAL CONTROL CARD - DIP SWITCH SELECTABLE (CON4)
- MANUAL SPEED CONTROL (STD. FACTORY PRE-SET)
- 0 - 10 VOLT INPUT
- MODBUS RTU NETWORK
- ROOM SIDE INFARED SPEED CONTROL (IR)
- REMOTE MOUNTED VISUAL CONTROL UNIT (CSL)

HOUSING FINISH:

- MIL FINISH ALUMINUM (STANDARD)
- POWER COAT PAINT (WHITE)
- 304 STAINLESS STEEL (ADD 3/8" TO OVERALL HEIGHT)

SCREEN FINISH:

- ANODIZED ALUMINUM (STANDARD)
- POWER COAT PAINT (WHITE)
- 304 STAINLESS STEEL

OPTIONS:

- 10" (254 mm) ALUM. DUCT COLLAR (10691 SHIPPED LOOSE)
- 12" (305 mm) ALUM. DUCT COLLAR (10789 SHIPPED LOOSE)
- POWER CORD - 115V ONLY (SHIPPED LOOSE)
(NOT ACCEPTABLE FOR PLENUM APPLICATIONS)
- IL - "GREEN" INDICATOR LIGHT
(ON = MOTOR RUNNING; OFF = MOTOR FAILURE)
- ILS-PSS - "RED" FILTER LOAD INDICATOR LIGHT
(ON = TIME TO CHANGE FILTER)
- CPR2X - (1) 1/8" FNPT ROOMSIDE CHALLENGE PORT AND
(1) 1/8" FNPT STATIC/CONCENTRATION PORT
- 0-10V OUTPUT SIGNAL WITH PRESSURE TRANSMITTER
FOR CONTINUOUS FILTER MONITORING.
- 3/4" KNIFE EDGE FOR CEILING GRID WITH GEL SEAL
(ADD 3/4" TO OVERALL HEIGHT).

CERTIFICATION:

- UL 507 LISTED (E152685)
- CE CERTIFIED
- IBC and OSHPD Certification (OSP-0634-10)
*Additional Hardware required, see submittal 8000024.

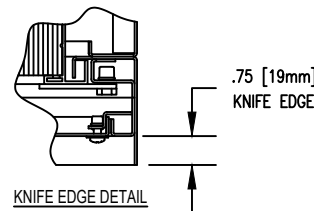
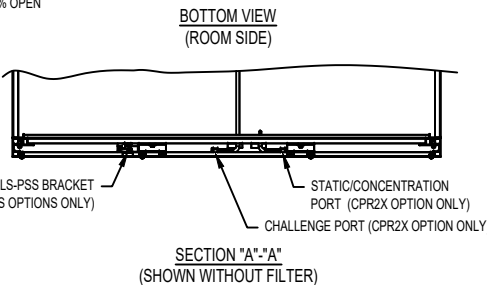
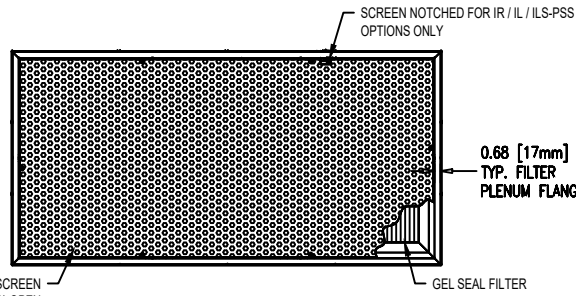
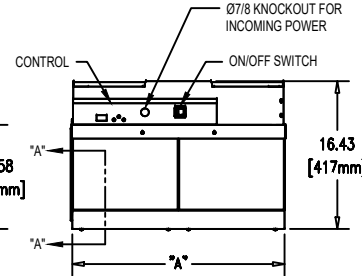
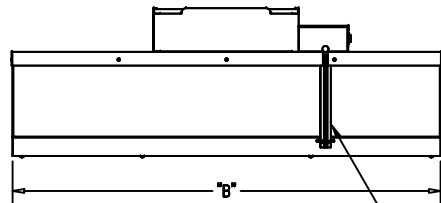
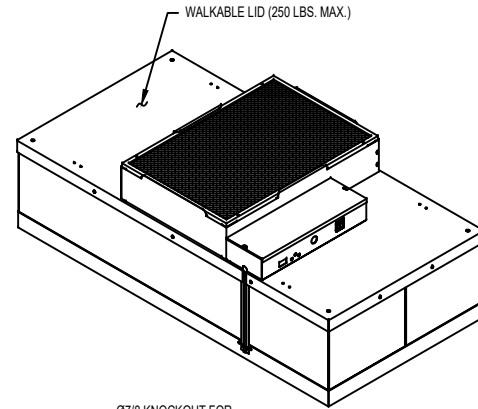
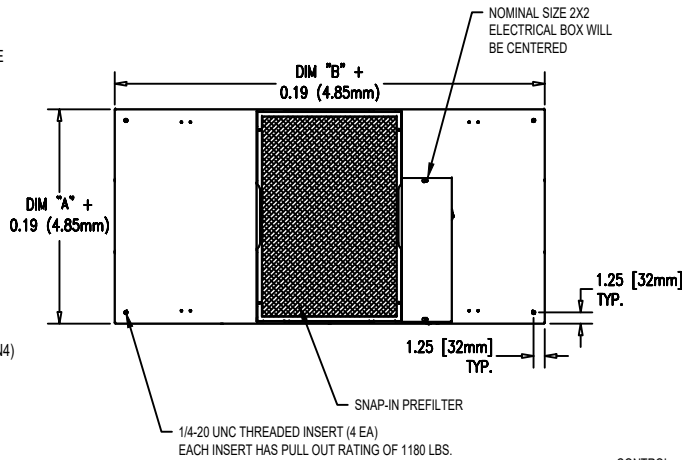

NOTE: LAF (LOW AIR FLOW) UNITS ARE NOT PROGRAMMED FOR CONSTANT CFM.

FILTER SIZE (OD)		NOMINAL FILTER SIZE	APPROX. WEIGHT	APPROX. AIRFLOW (CFM)***
DIM "A" in (mm)	DIM "B" in (mm)			
<input type="checkbox"/> 23.63 (600)	47.63 (1210)	2X4	(ALUM.)	MIN. = 70 MAX. = 508
<input type="checkbox"/> 23.50 (597)	47.50 (1207)		71 lbs	
<input type="checkbox"/> 23.25 (591)	47.25 (1200)		32 Kgs (SST)	
<input type="checkbox"/> 23.13 (588)	47.13 (1197)		81 lbs	
<input type="checkbox"/> 23.00 (584)	47.00 (1194)		37 Kgs	
<input type="checkbox"/> 23.03 (585)	46.63 (1185)	2X3.5	(ALUM.)	MIN. = 60 MAX. = 488
<input type="checkbox"/> 23.63 (600)	41.63 (1057)		62 lbs	
<input type="checkbox"/> 23.50 (597)	41.50 (1054)		28 Kgs (SST)	
<input type="checkbox"/> 23.25 (591)	41.25 (1048)		72 lbs	
<input type="checkbox"/> 23.13 (588)	41.13 (1045)		33 Kgs	
<input type="checkbox"/> 23.00 (584)	41.00 (1041)	2X3	(ALUM.)	MIN. = 53 MAX. = 485
<input type="checkbox"/> 23.03 (585)	40.75 (1035)		54 lbs	
<input type="checkbox"/> 23.63 (600)	35.63 (905)		24 Kgs (SST)	
<input type="checkbox"/> 23.50 (597)	35.50 (902)		64 lbs	
<input type="checkbox"/> 23.25 (591)	35.25 (895)		29 Kgs	
<input type="checkbox"/> 23.13 (588)	35.13 (892)	2X2	(ALUM.)	MIN. = 49 MAX. = 402
<input type="checkbox"/> 23.00 (584)	35.00 (889)		44 lbs	
<input type="checkbox"/> 23.03 (585)	34.84 (885)		20 Kgs (SST)	
<input type="checkbox"/> 23.63 (600)	23.63 (600)		54 lbs	
<input type="checkbox"/> 23.50 (597)	23.50 (597)		24 Kgs	
<input type="checkbox"/> 23.25 (591)	23.25 (591)	**OTHER	N/A	N/A
<input type="checkbox"/> 23.13 (588)	23.13 (588)			
<input type="checkbox"/> 23.00 (584)	23.00 (584)			
<input type="checkbox"/> 23.03 (585)	23.03 (585)			

** CONTACT MFG. TO INSURE SIZE AVAILABILITY.

*** SETTINGS: MINIMUM PWM = 5% / MAXIMUM PWM = 100%

SIGNATURE _____

DATE _____

COMPANY _____

PROJECT _____

P.O. _____



101 McNeill Rd,
Sanford, NC 27330
PHONE: 919-775-2201
PHONE: 1-800-884-0002
FAX: 1-800-458-2379
www.enviroco.com
email: enviroco@enviroco.com

MAC10 IQ LAF
RSR/RSRE

(UNITS PROGRAMMED FOR LOW AIR FLOW)

UNLESS SPECIFIED ALL DIMENSIONS ARE IN INCHES. TOLERANCE .XX±.03 .XXX±.015 ANGULAR ±1° UNLESS NOTED

THIS DRAWING IS THE PROPERTY OF ENVIRCO, AND MAY NOT BE REPRODUCED OR PUBLISHED WITHOUT AUTHORIZATION FROM ENVIRCO.

COPYRIGHT 2010 ENVIRCO

DRAWING NO: 8000014	
DATE: 4-4-14	DRAWN BY: AMO
REV: B	REV DATE: 7-21-20
DESIGN PLAN ECN-52264	