

**PRODUCT DATA SHEET**

**EOS-60 FFU Control**

The EOS-60 is a compact, field configurable 2.8" Color Touchscreen Console that intelligently controls & monitors Fan Filter Units (FFUs) from several leading manufacturers. The size of a light switch, it expands up to 4 Room/Zones and 60 FFUs. This 2.8" color, high-resolution TFT screen is easily wall-mounted with an external panel box or flush mounted into your wall using a standard electrical single-gang box. Certifier/Commissioning friendly with setpoint adjustment and CFM & RPM feedback. Every EOS-60 comes with an EOS-60 PCM to provide power to the touchscreen and communication to the FFUs. The EOS-60 PCM makes installation a true plug and play solution with the touchscreen.



**Main Functions**

- Touch Capable Icons
- Menu Driven configuration options
- Monitors FFUs
- Global FFU Speed Adjustment
- Global FFU Set-back Speed Adjustment
- FFU Speed Control
- Central Monitoring of fault conditions
  - Pressure Switch Feedback — AC FFU
  - RPM Feedback — EC FFU
  - CFM Feedback — CFM FFU
- Multiuser capability: Admin or View only mode
- Error Logging
- Supports 3 protocols to BMS
  - MODBUS RTU
  - MODBUS TCP/IP\*
  - BACnet MSTP/IP\*\*

\*Requires ACGW001-EOS gateway to provide MODBUS TCP/IP protocols

\*\*Requires ACGW007-EOS gateway to provide BACnet protocols

Color Coded Mode and Status	
RUN	Normal operating speed
STANDBY	Setback operating speed
AUTO (Run/Standby)	Automatic operating speed
STOP	Stops the FFU from operating
OFFLINE	Disables communication from the EOS to the FFU
ERROR	Reports an error in the FFU

**Features**

- Compact and fits in a single gang junction box
- 2.8" Color touchscreen
- Supports up to 60 FFUs
- Supports up to 4 Zones
- Built in Buzzer for alarming
- Multiuser capability: View or Admin

**System Diagram**

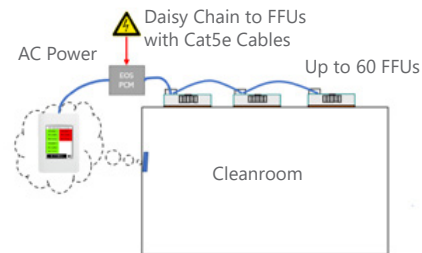

**PRODUCT DATA SHEET**
**EOS-60 FFU Control**

Part No.	Model No.	FFUs	Groups	Defining Feature	Display	BACnet
272740-001	EOS-60	60	4	RPM feedback, group control	2.8" touchscreen	no
272740-002	EOS-60BGW	60	4	RPM feedback, group control, BMS Comm.	2.8" touchscreen	yes
272740-003	EOS-NST	255	n/a	Network Scan Tool-Perfect for Startups	2.8" touchscreen	n/a

Main Functions	
FFU Types	EC FFU- RPM Feedback CFM FFU-CFM Feedback AC FFU- Pressure Switch Fault Feedback
Room Control	Up to 4 Rooms
User Interface	Color Touchscreen
Number of FFUs to Control	Up to 60 FFUs
Password Protection	Yes, Admin and View modes available
Communication Protocol	Modbus, RTU, RS485 2 Wire for FFU Control Modbus TCP/IP Ethernet for BMS intergration
Display	
Type	LCD 2.8 TFT Resolution 240x320x16
Backlight Life	20,000 Hours
Brightness	160cd/m <sup>2</sup>
Touch Panel	Yes
Environmental	
Operating Temperature	-20~ + 70°C
Storage Temperature	-30~ + 80°C
Humidity	10~ 90% RH

Features	
Hierarchal Mode and Speed Control Levels	Global All Room speed and mode adjustment Individual room speed and mode adjustment Individual FFU speed and mode adjustment
Zone Control	Up to 4 Zones
Alarm	Buzzer, Color-coded icon and flashing screen
Date/Time	Real Time Clock
Event Log	Logs up to 2560 Events Ex. Communication Error or Changes in Setup to Console
Mechanical	
Touchscreen Dimensions	4.65in x 2.95in x 1.27in 118mm x 76mm x 32mm
Installation of Touchscreen	Wall Mounting
Ingress Protection Rating	Front Panel: IP40
Power	
Consumption of Touchscreen	1.5w
EOS-60 PCM or PCMGW	100-240 VAC, 9A 50/60Hz
Touchscreen	+12~ 48 VDC
HMI	
Buzzer	Yes
Ethernet	
Ports	RJ-45 x 1, 10/100 Base- Tx

**PRODUCT DATA SHEET**

**EOS-60 Dimensions**

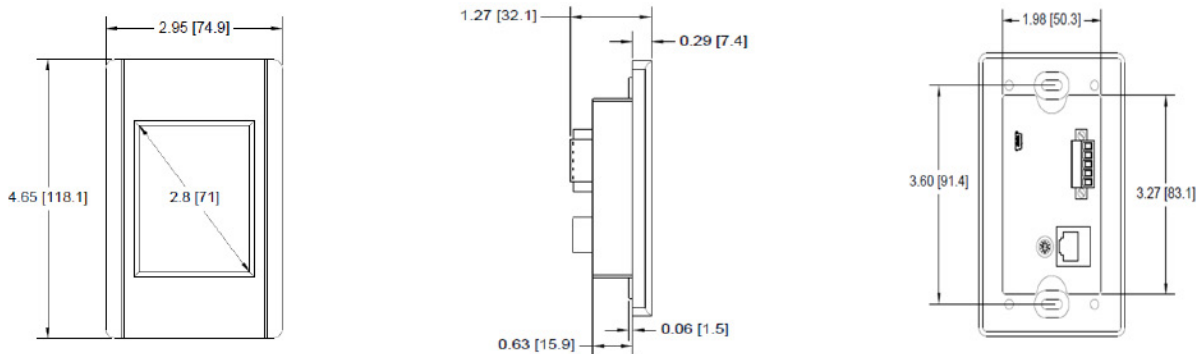

**EOS-60 Power Communication Module (EOS-60 PCM)**

- Provides power to the EOS-60
- Provides communication to the EOS-60/FFU Daisy Chain through the Hub board included
- High Voltage is wired into box and stepped down using Switch Mode Power Supply
- AC Power Requirements
  - 100-240 VAC, .9A 50/60Hz
    - EOS-60 PCM provides 24VDC, 1.5A for EOS-60
    - EOS-60 PCM comes in two configurations
  - EOS-60 PCM standalone system
  - EOS-60 PCM-GW includes ACGW-EOS1201 gateway for BACnet IP or MS/TP integration

\*BACnet® is a registered trademark of ASHRAE

**EOS-60 PCM-GW Dimensions**

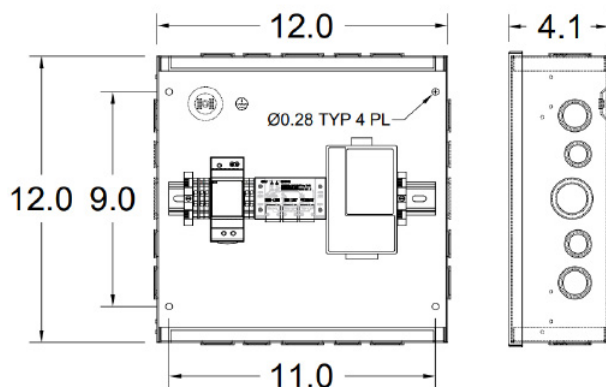

**EOS-60 PCM Dimensions**

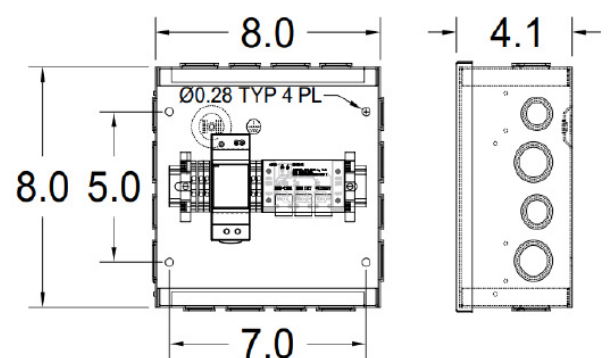

ENVIRCO USA | 101 McNeill Road | Sanford, NC 27330

Tel: 919.775.2201 | Toll Free: 800.884.0002 | Fax: 800.458.2379 | [www.envirco.com](http://www.envirco.com)