

*****READ AND SAVE THESE INSTRUCTIONS*****



MAC 10[®] RFAC
Fan Filter Unit

INSTALLATION, OPERATION & MAINTENANCE MANUAL

Table of Contents

Important Information	3
Contact Information	3
Critical Operations of the MAC 10 [®] RFAC	4
Warnings	4
Part Numbers	4
Installation	5
Unit Control Box	6
Control Card (Optional)	6
Changing the Prefilter.....	7
Changing the Exhaust Direction.....	8
Removal and Replacement of Standard HEPA/ULPA Filters	9
Removal and Replacement of RSR HEPA/ULPA Gel Seal Filters	10
Motor Removal and Installation.....	11
Troubleshooting.....	12
MAC 10 RFAC Wiring Diagrams	13
MAC 10 RFAC Replacement Parts Diagrams	14
Limited Warranty	15
Testing	15

Installation, Operation, & Maintenance Manual

■ **Important Information**

To ensure ordering of the proper replacement parts or complete MAC 10 unit, record the information from the serial number label, located adjacent to the electrical box, in the fields below for easy future reference. If you cannot locate the Sales Order Number, please contact ENVIRCO for this information.



Serial No. Label

Company Purchased From _____

ENVIRCO Job Number _____

Order Number _____

Serial Number _____

Unit Part Number _____

Date _____

Airflows per Certification _____

■ **Contact Information**

ENVIRCO USA
101 McNeill Road
Sanford, NC 27330
Tel: (919) 775-2201
Tel: (800) 884-0002
Fax: (800) 458-2379
Email: info@envirco.com

Installation, Operation, & Maintenance Manual

■ Critical Operation Conditions of the MAC 10 RFAC

1. Touching the HEPA filter will damage it and will void the filter warranty. The screen is only to protect against an accidental 'touch' of the filter. Never place a hand or tool on the filter. Never lie filter face flat down on a surface; always have filter on its side to protect from damage.
2. Prior to powering the unit, verify the voltage on the label and that the unit has been wired to the correct voltage. The serial number label on the top of the MAC 10 unit has the required voltage, as shown on page 3.

■ Warning

TO REDUCE THE RISK OF FIRE, ELECTRICAL SHOCK, OR INJURY TO PERSONS, OBSERVE THE FOLLOWING:

- A. Installation work and electrical wiring must be done by qualified person(s) in accordance with all applicable codes and standards, including fire-rated construction.
- B. When cutting or drilling into wall or ceiling, do not damage electrical wiring and other hidden utilities.
- C. If this unit is to be installed over an area using liquid, such as water or chemical cleaning solutions, it must be marked as appropriate for the application.
- D. Use this unit only in the manner intended by the manufacturer. If you have any questions, contact the manufacturer.
- E. Before servicing or cleaning the unit, switch power off at unit service panel and lock service panel to prevent power from being switched on accidentally.
- F. NOTE – The Mac 10 has not been investigated for use in fire resistance rated construction.
- G. To fulfill our obligations towards Article 33, in accordance to European REACH Regulation No 1907/2006 EC, we hereby inform you that this article contains the following Substances of Very High Concern mentioned on the Candidate list:
Cadmium/ 1,3,5-triglycidyl-s-triazinetriene

■ Part Numbers Covered by This Manual

Standard Filter		RSR Filter	
2x4 120V HEPA	11260-001	2x4 120V HEPA	11264-001
2x4 277V HEPA	11260-003	2x4 277V HEPA	11264-003
2x2 120V HEPA	11263-001	2x2 120V HEPA	11267-001
2x2 277V HEPA	11263-003	2x2 277V HEPA	11267-003

Note: A "Z" in the part number indicates that the unit is special. This may indicate a size change from standard or a special filter. Please contact the factory for part numbers if this is the situation.

Installation, Operation, & Maintenance Manual

■ **Installation**

Note: The MAC 10 RFAC Fan Filter Unit is completely assembled at the factory with the exception of the optional 1/4-20 eyebolts that are used when hanging the unit from an engineered support system and with installation of the HEPA/ULPA filters. (Eyebolts are not included and need to be ordered separately, p/n 222449-001.)

Step 1. Carefully remove the unit from the shipping carton and inspect for any damage that may have occurred during transportation. (See Figure 1.)

Note: When ordering RSR units, the HEPA filters may be shipped separately to be installed into units after the fan box has been installed.

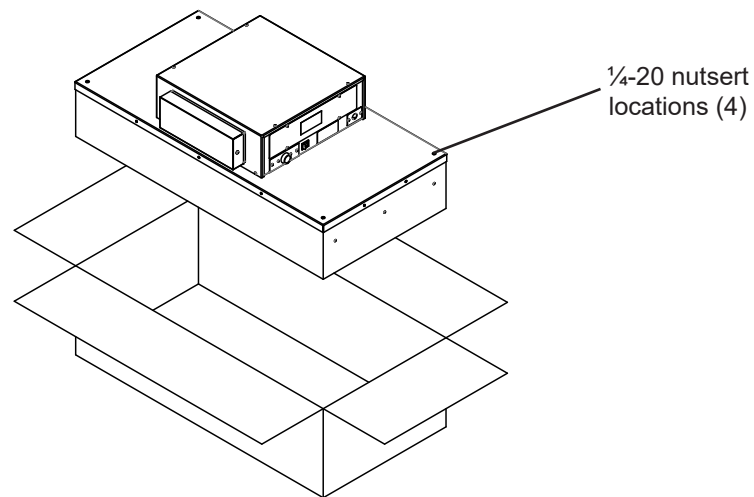

Figure 1: Unboxing

Step 2. Wipe down plastic bag and move unit into cleanroom. (Double bagging is available upon request.)

Step 3. If using rigidly supported grid (usually 2" (50 mm) or wider), raise unit through ceiling and lower onto the gasketed grid. If using a flexible grid (typically supported with wires), the unit must be secured to an engineered support system with eyebolts, s-hooks, and chain. Screw the four eyebolts into the nutserts on the lid assembly before lifting into an overhead position. (See Figure 1, above.)

Note: Confirm fan dimensions to match T-Grid dimensions. Special size units are available to fit specific cleanroom grid systems.

Step 3.1. If using a support grid, continue...

Step 4. Raise the unit and secure it into place.

Step 5. Have an electrician wire the unit to the appropriate voltage, according to the wiring diagram (page 13), and all national and local electrical codes. If optional power cord was purchased, plug unit into a grounded receptacle. The optional power cord is not acceptable for plenum installations.

Step 6. Turn on the power using the rocker switch (ON/OFF) located on the electrical box.

Note: Your fan filter controls may have been shipped separately.

Installation, Operation, & Maintenance Manual

■ Unit Control Box

ON/OFF Switch - Speed/Airflow Adjustment

MAC 10 RFAC units are equipped with a two-position rocker switch (ON/OFF) and Solid State Speed Control (SSSC), which are located on the front side of the electrical box. (See Figure 2.)

Recommended fan speed during initial start-up and operation is at a low speed. As airflow eventually decreases due to filter loading, fan speed may be increased by moving the SSSC first to a medium speed and eventually to a high speed. Periodic airflow readings (per IEST specifications) should be conducted to determine the filter condition and appropriate fan setting.

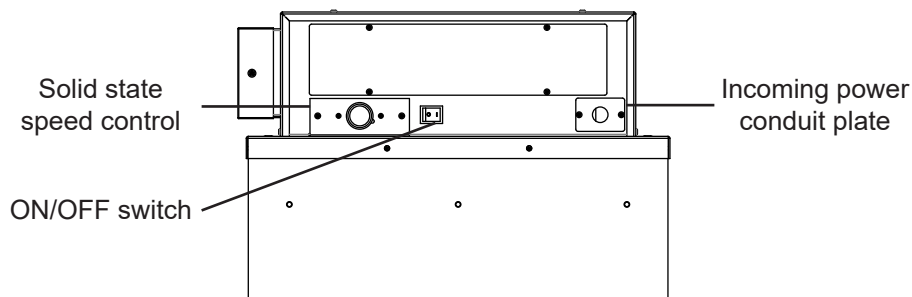

Figure 2: SSSC Speed/Airflow Adjustment

■ TPC Speed Control Card (Optional)

MAC 10 RFAC units will have the capability to include a unique control card in lieu of the SSSC for networking purposes. Contact the factory for part number.

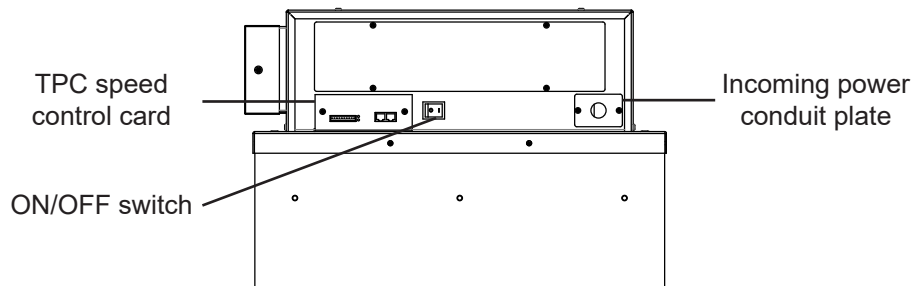

Figure 3: TPC Speed/Airflow Adjustment

Installation, Operation, & Maintenance Manual

■ **Changing the RFAC Prefilter (RSR Only)**

Tools Required: None.

Note: To keep the filter in top operating condition, replacing the pleated prefilter is recommended every twelve months or sooner.

The 2x2 FFU has (1) MERV 8 20" x 20" x 1" pleated filter, while the 2x4 FFU has (2) MERV 8 20" x 20" x 1" pleated filters.

Step 1. To gain access to the prefilter, pull out the perforated prefilter front door clips to unlatch the door.

Step 2. Swing open the perforated prefilter door.

Step 3. Remove and replace the pleated filter(s).

Step 4. Complete by reversing the above steps.

WARNING
DISCONNECT THE UNIT FROM THE
ELECTRICAL POWER SOURCE BEFORE
ATTEMPTING ANY SERVICE.

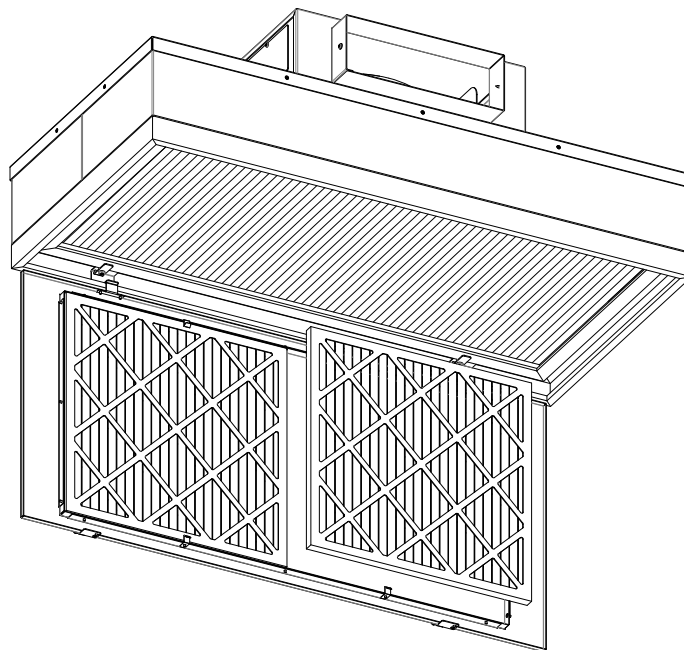

Figure 4: Prefilter Replacement

■ Changing the Exhaust Direction

Prior to installation, the required exhaust direction should be determined by the installer. The RFAC exhaust direction can be changed to one of any four directions (in 90° increments from the position as shown in Figure 5).

WARNING

DURING THE PROCESS OF CHANGING THE EXHAUST DIRECTION, TAKE SPECIAL CARE NOT TO OVERTIGHTEN THE SHEET METAL SCREWS. THIS WILL CAUSE THE SHEET METAL HOLES TO BE STRIPPED OUT, AND AS A RESULT, THE BLOWER HOUSING AND/OR THE BLOWER COVER WILL NOT BE PROPERLY SECURED.

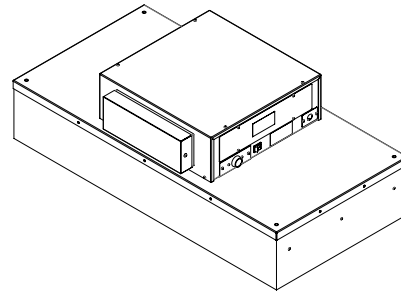

Figure 5: RFAC

To change to the opposite direction of the RFAC's current exhaust direction:

Step 1. Remove the eight screws that secure the blower cover to the blower housing. (See Figure 6.)

Step 2. Rotate the cover 180°.

Step 3. Re-install the cover using the eight screws to secure the cover. (See Figure 7.)

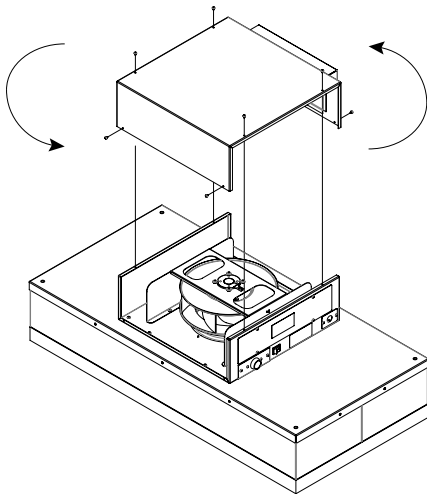

Figure 6: Opposite Exhaust Direction Change

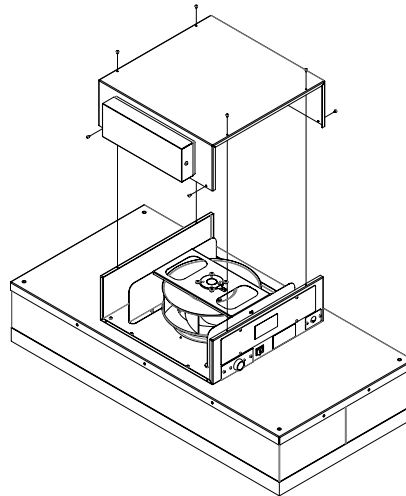

Figure 7: Reinstalling the Blower Cover

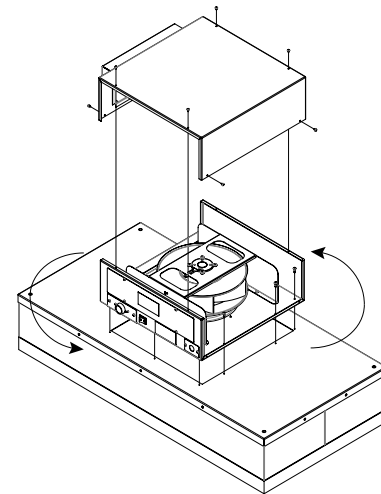

Figure 8: 90° Exhaust Direction Change

To change to a direction 90° of the RFAC's current installed direction:

Step 1. Remove the eight screws that secure the blower cover to the blower housing. Set the cover aside.

Step 2. Remove the ten screws that secure the blower housing to the lid panel.

Step 3. Rotate the blower housing 90° in either direction. (See Figure 8.)

Step 4. Re-install the ten screws that secure the blower housing to the lid panel.

Step 5. Re-install the cover using the eight screws to secure the cover, in the desired exhaust direction. (See Figure 7.)

Installation, Operation, & Maintenance Manual

■ **Removal and Replacement of Standard HEPA/ULPA Filters**

WARNING

DISCONNECT THE UNIT FROM THE ELECTRICAL POWER SOURCE BEFORE ATTEMPTING ANY SERVICE.

WARNING

THE STANDARD FILTER IS PROTECTED WITH AN EXPANDED METAL FACE SCREEN. THIS IS NEVER TO BE USED TO HANDLE THE FILTER. IT IS ONLY FOR PROTECTION AGAINST AN ACCIDENTAL TOUCH OF THE FILTER. ONLY HANDLE THE FILTER BY THE FRAME.

Note: All filters should be visually inspected for freight damage before installation. It is necessary to use two workers when removing the filter and for installation to avoid twisting or separation of the media seals. Handle the filter only by the frame and never place anything on the upstream filter side of the filter. Additionally, it is important to keep the filter level to prevent any shearing force on the media itself.

For Standard Filters:

Tools Required: Phillips head screwdriver, rivet hand tool, Ø5/32 aluminum rivet grip range .126-.187

Step 1. Remove unit from ceiling.

Step 2. Remove the screws holding the filter to the lid assembly.

Step 3. Lift the lid assembly off the filter. (See Figure 9.) Discard the used filter as per requirements of the applicable regulations.

Note: Before replacing with a new filter, carefully inspect the new filter for any visual damage. Also, inspect the gasket in the “tee” bar to ensure a tight seal. Replace as necessary.

Step 4. Install rivets in ends to plug unused holes in new filter.

Step 5. Replace with the new filter and complete by reversing the above steps.

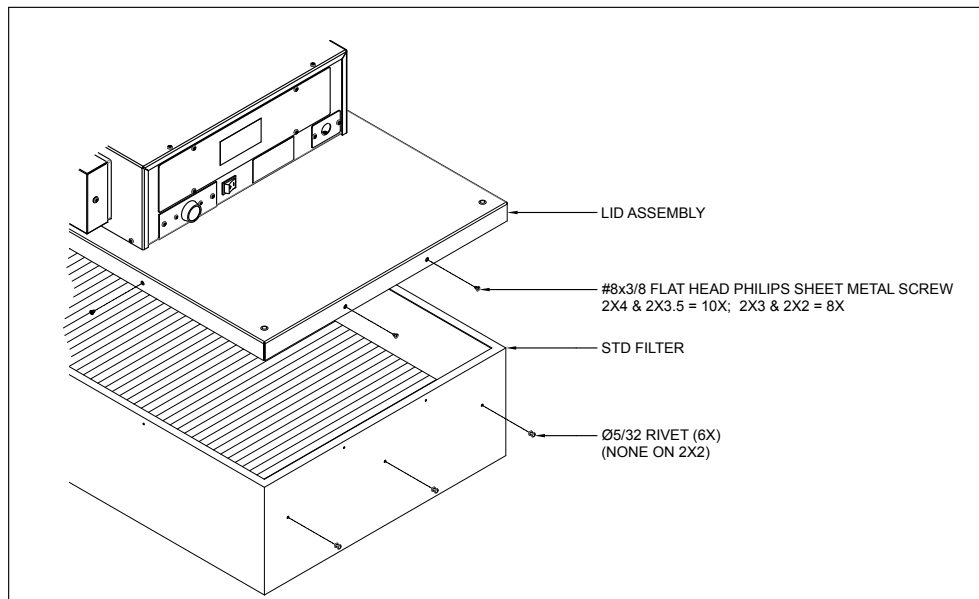

Figure 9: Standard Filter Replacement

Installation, Operation, & Maintenance Manual

■ Removal and Replacement of RSR HEPA/ULPA Gel Seal Filters

WARNING

DISCONNECT THE UNIT FROM THE ELECTRICAL POWER SOURCE BEFORE ATTEMPTING ANY SERVICE.

WARNING

THE RSR FILTER IS PROTECTED WITH AN EXPANDED METAL FACE SCREEN. THIS IS NEVER TO BE USED TO HANDLE THE FILTER. IT IS ONLY FOR PROTECTION AGAINST AN ACCIDENTAL TOUCH OF THE FILTER. ONLY HANDLE THE FILTER BY THE FRAME.

Note: All filters should be visually inspected for freight damage before installation. It is necessary to use two workers when removing the filter and for installation to avoid twisting or separation of the media seals. Handle the filter only by the frame and never place anything on the upstream filter side of the filter. Additionally, it is important to keep the filter level to prevent any shearing force on the media itself.

For RSR Filters:

Tools Required: Phillips head screwdriver

Step 1. To gain access to the filter, pull out the perforated prefilter door clips to unlatch the perforated pre-filter doors.

Step 2. Swing open the perforated prefilter door.

Step 3. Inspect filter for visual damage. If damaged, set aside for replacement or repair.

Step 4. Inspect the gel seal if reinstalling the removed filter. Determine if the gel has lost its ability to seal. If so, have a certified professional replace the missing, dried out, and/or severely damaged gel.

Step 5. Place the filter evenly against the filter plenum housing of the RSR unit. Install filter clips and screws. The clips can be rotated and angled into place. Using the clips as a lever, the filter can be seated. It is recommended to work either clockwise or counter-clockwise around the filter and raise the filter into the gel.

Step 6. Close and re-latch perforated prefilter door.

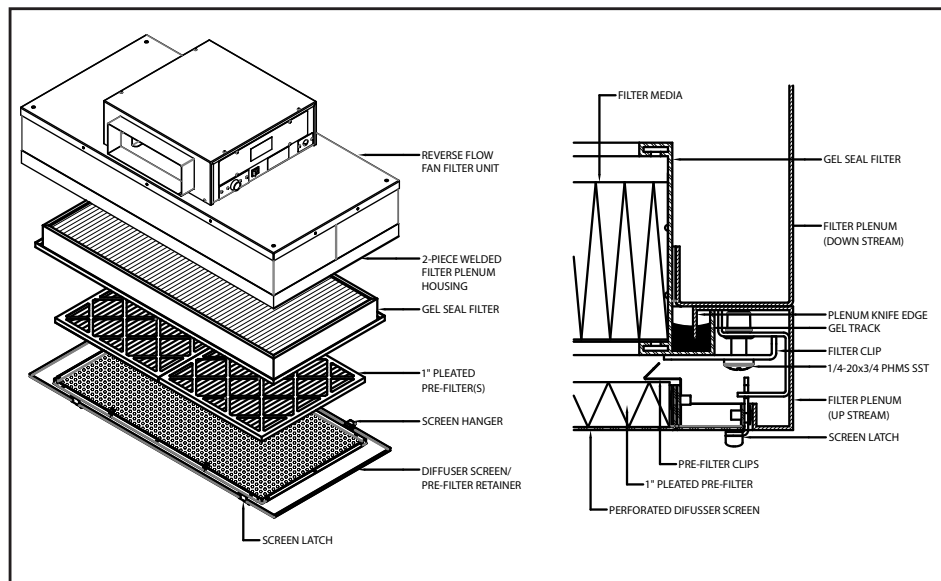

Figure 10: RSR Filter Replacement

Installation, Operation, & Maintenance Manual

■ **Motor Removal and Installation**

WARNING

DISCONNECT THE UNIT FROM THE ELECTRICAL POWER SOURCE BEFORE ATTEMPTING ANY SERVICE.

WARNING

ELECTRICAL SERVICE SHOULD ONLY BE PERFORMED BY LICENSED ELECTRICIANS OR AUTHORIZED ENVIRCO SERVICE TECHNICIANS.

Tools Required: Phillips head screwdriver, wire cutters to remove tie-down and install replacement tie-downs

Step 1. To gain access to the motor, you must have access to the top of the unit.

Step 2. Switch the ON/OFF switch to the OFF position.

Step 3. Disconnect incoming power connections.

Step 4. Remove the screws to free the motor/blower cover. (See Figure 8.) If using power drivers, set the unit to a low torque setting to avoid stripping the sheet metal screws (See Figure 11.)

Step 5. Disconnect motor wire harness connector.

Step 6. Remove the four screws mounting the blower bracket to the blower assembly plate, and cut cable tie securing blower cable to blower bracket. Remove motor mount assembly from plate.

Step 7. Remove the four screws mounting the blower to the blower bracket. (Note orientation of blower cable to bracket.)

Step 8. Install new motor/blower and components previously removed in reverse order to complete work.

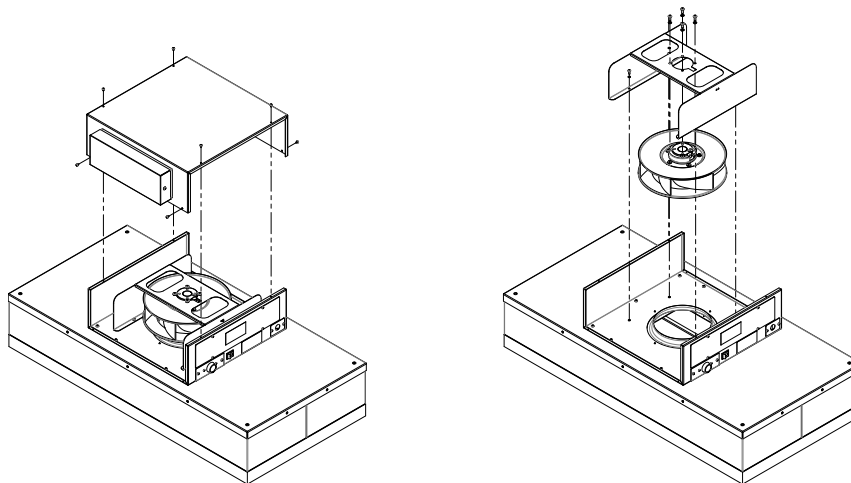

Figure 11: Motor Replacement

■ Troubleshooting

IF LOW AIR VELOCITY

Step 1. Check prefilter media; replace or clean as necessary.

Step 2. Adjust SSSC clockwise for higher blower output.

Step 3. Check power supply for proper voltage, amperage, and distribution frequency.

Step 4. Replace HEPA filter if the air velocity remains low.

IF HIGH AIR VELOCITY

Adjust SSSC counterclockwise for lower blower output.

NON-LAMINAR FLOW AND/OR EXCESSIVE CONTAMINATION

Step 1. Ensure that no large obstructions are upstream of airflow pattern.

Step 2. Determine that no other air-moving devices are operating in or around cleanroom which disrupt room's airflow pattern.

Step 3. Check air velocity and, if low, conduct the "Low Air Velocity" procedure outlined above.

Step 4. Conduct smoke and photometer test on HEPA filter. Seal or replace HEPA filter as necessary.

Contact Technical Support at:

ENVIRCO

101 McNeill Road

Sanford, NC 27330, USA

Tel: (800) 884-0002

Fax: (800) 458-2379

Email: info@envirco.com

Installation, Operation, & Maintenance Manual

■ **MAC 10 RFAC Wiring Diagrams**

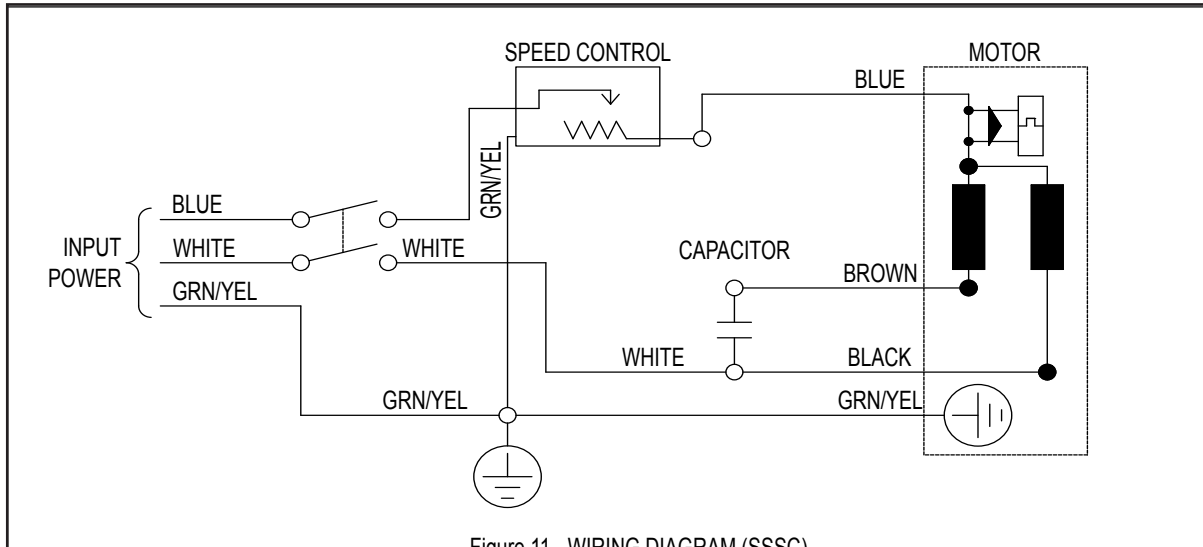
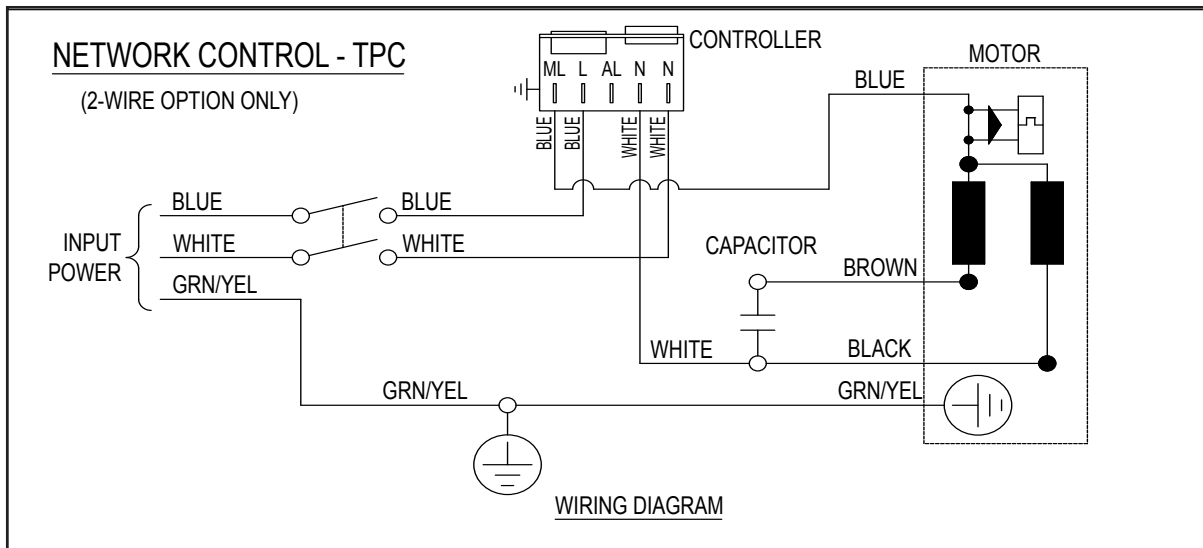

Figure 11: WIRING DIAGRAM (SSSC)

Figure 12: Wiring Diagram (SSSC)



WIRING DIAGRAM

Figure 13: Wiring Diagram (TPC)

MAC 10[®] RFAC

Fan Filter Unit



Installation, Operation, & Maintenance Manual

MAC 10 RFAC Replacement Parts Diagrams

Standard Style

RSR Style

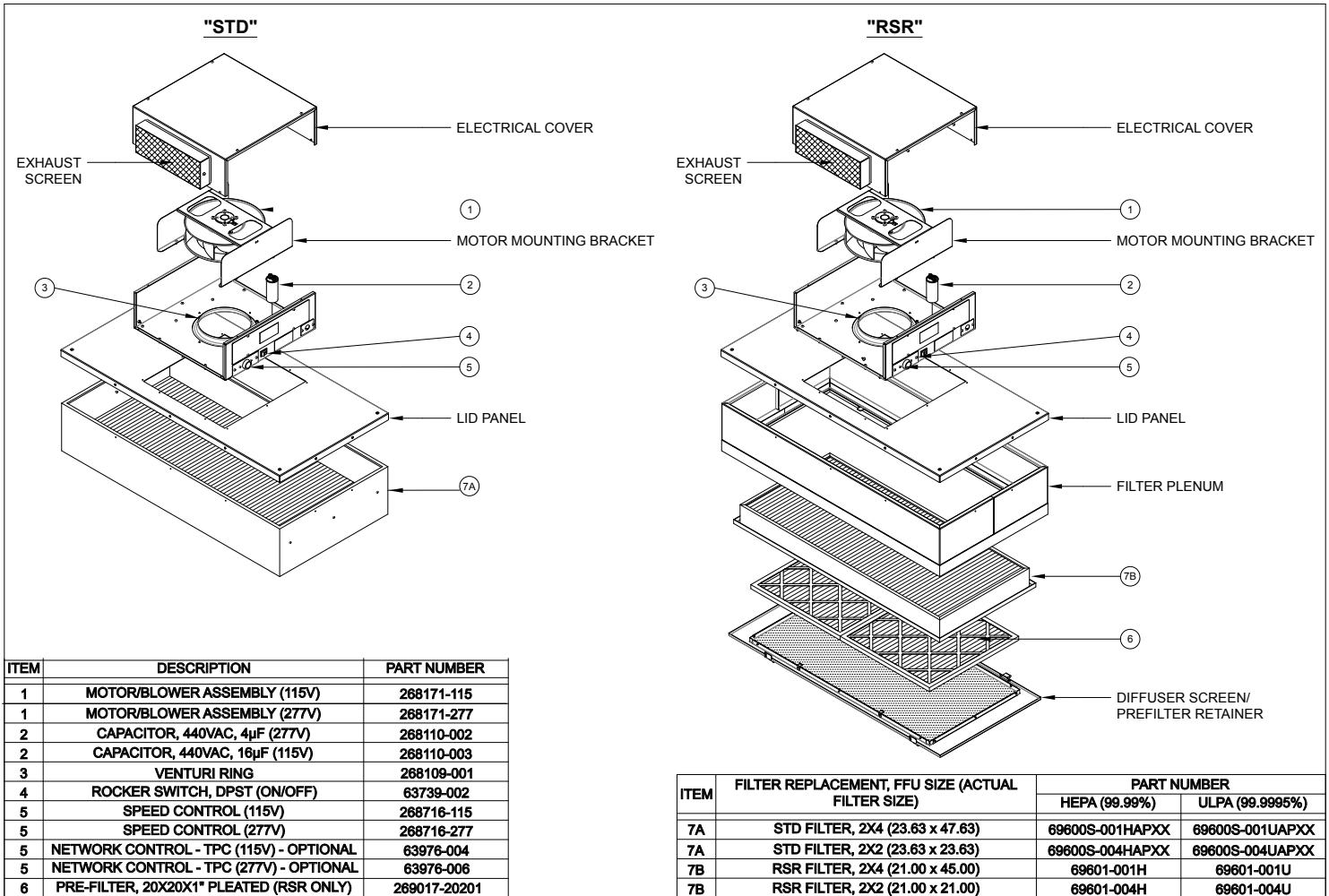

Installation, Operation, & Maintenance Manual

■ Limited Warranty

LIMITED WARRANTY: Unless otherwise expressly stated in ENVIRCO's published specifications for the Goods, ENVIRCO warrants that Goods are free from defects in material and workmanship, except for services which are warranted to be performed in a competent and diligent manner in accordance with any mutually agreed specifications. The foregoing warranty shall apply for eighteen (18) months from the date of shipment from ENVIRCO's facility, except for services for which the warranty shall apply for ninety (90) days from the date of performance (the "Warranty Period"). Provided Buyer informs ENVIRCO in writing of any breach of warranty prior to the expiration of the applicable Warranty Period, ENVIRCO shall, as its sole obligation and Buyer's sole and exclusive remedy for any breach of this warranty, repair or replace/re-perform the Goods which gave rise to the breach or, at ENVIRCO' option, refund the amounts paid by Buyer for the Goods which gave rise to the breach. Any repair, replacement or re-performance by ENVIRCO hereunder shall not extend the applicable Warranty Period. The parties shall mutually agree on the specifications of any test to determine the presence of a defect. Unless otherwise agreed upon by ENVIRCO in writing, Buyer shall bear the costs of access, de-installation, re-installation and transportation of Goods to ENVIRCO and back to Buyer. These warranties and remedies are conditioned upon (a) the proper storage, installation, operation, and maintenance of the Goods and conformance with the proper operation instruction manuals provided by ENVIRCO or its suppliers or subcontractors, (b) Buyer keeping proper records of operation and maintenance during the applicable Warranty Period and providing ENVIRCO access to those records, and (c) modification or repair of the Goods only as authorized by ENVIRCO. ENVIRCO does not warrant the Goods or any repaired or replacement parts against normal wear and tear or damage caused by misuse, accident, or use against the instructions of ENVIRCO. Any modification or repair of any of the Goods not authorized by ENVIRCO shall render the warranty null and void. EXCEPT AS EXPRESSLY SET FORTH HEREIN, ENVIRCO MAKES NO OTHER WARRANTIES, EXPRESS OR IMPLIED, INCLUDING, BUT NOT LIMITED TO, ANY IMPLIED WARRANTIES OF MERCHANTABILITY, NON-INFRINGEMENT OR FITNESS FOR A PARTICULAR PURPOSE WHICH ARE HEREBY DISCLAIMED TO THE EXTENT PERMITTED BY APPLICABLE LAW.

■ Testing

Each MAC 10 RFAC filter unit is thoroughly tested at the factory before shipment. However, because of the "rigors" of shipping, ENVIRCO encourages its re-test after installation.

ENVIRCO recommends that the customer contact an independent organization, with technicians trained and experienced in performance evaluation and maintenance of clean air equipment.

HEPA filters (Type J) are tested to IEST-RP-00034. ULPA filters are tested to (Type F) IEST-RP-00034. All filters are UL 900 recognized. Your filters may have special requirements; please see original engineering specifications for your specific project.

All units that are airflow tested at ENVIRCO are tested using a Shortridge Airdata Multimeter 870 with a Velgrid head. The recommended method of reading is to place one corner of the Velgrid head 1-1/4" from the corner of the filter face, take four readings evenly spaced along the four foot side, then repeat these reads three additional times. This gives a total of eight readings to test the unit. All advertised data is based on using the Velgrid with eight readings (128 velocity points). ENVIRCO recognizes that using eight readings during a cleanroom start-up may be time-consuming and recommends that using four Velgrid readings taken on each 2x2 filter section will approximate the same as eight readings.

Clean air solutions built for you.

MORE INFORMATION AVAILABLE AT WWW.ENVIRCO.COM

Industrial

Cleanroom Products

- » MAC 10® Original
- » MAC 10® IQ™
- » MAC 10® IQ™ LAF
- » MAC 10® LEAC™
- » MAC 10® LEAC2™
- » MAC 10® LEDC™
- » MAC 10® RFAC
- » Ducted Ceiling Module:
DCM & RSR
- » AC or DC Control Systems
- » MAC-T Ceiling Grid System

Hospital & Healthcare

Hospital & Healthcare

- » IsoClean® and IsoClean
with Ultraviolet Light
 - » AirCeil®
 - » Hospi-Gard® Room
Pressure Monitor
- ### Enviramedic Products
- » HOR Horizontal Flow
Enclosure
 - » HCF Horizontal Flow
Surgery Room
 - » VOR Vertical Flow Surgery
Isolator

Pharmaceutical

Pharmaceutical & Medical Device

- » Unimodule M2 Vertical
Laminar Flow Workstation
- » METD 100% Exhausted
Vertical Flow Workstation
- » Laminar Downflow Module

Laboratory & Research

Laboratory & Research

- » 100-Plus Horizontal or
Vertical Flow Clean Bench
- » Unidirectional Flow
Horizontal Flow Bench (LF)
- » TT Table Top Horizontal
Flow Clean Bench
- » EnviraLab Sterility Module:
ESM

